

ISSUE	MOD No.	INITIAL/DATE
A		INTRODUCTION OF PART GU 28-08-09
B		UPDATED TO DUAL DIMS. RSR 25-06-13

Ø181.0mm [7.13 in.]

385.1mm [15.17 in.]

170.6mm [6.72 in.]

235.0mm [9.25 in.]

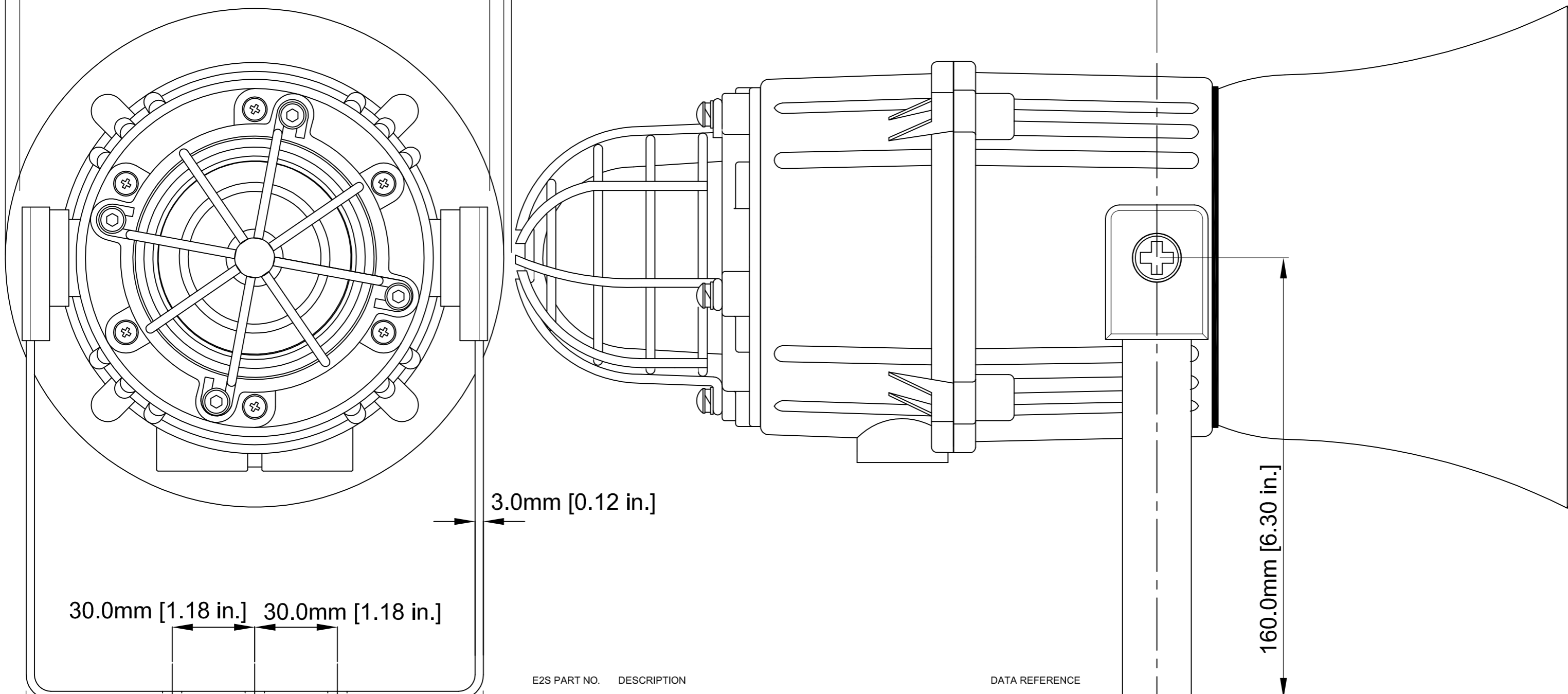

3.0mm [0.12 in.]

30.0mm [1.18 in.] 30.0mm [1.18 in.]

160.0mm [6.30 in.]

166.0mm [6.54 in.]

3 Holes Ø 7.0 [0.28 in.]

E2S PART NO.	DESCRIPTION	DATA REFERENCE
E2xCS112-5...	E2xCS112-5 COMBINED ALARM SOUNDER & XENON STROBE BEACON	1.33.010
HMCA112-05...	HMCA112-05 ELECTRONIC SIREN, BUZZER, HOOTER & BELL	2.33.050
MCA112-05...	MCA112-05 ALARM SOUNDER & XENON BEACON	2.31.400
MCA112-L1...	MCA112-L1 ALARM SOUNDER & LED BEACON	2.31.410

WHERE APPLICABLE '-UL' VERSIONS ARE COVERED BY THIS OUTLINE DRAWING.

DRAWING TO BS8888:2000 GEOMETRIC TOLERANCES TO ISO1101:1983 LINEAR DIMENSIONAL TOLS ANGULAR DIMENSIONAL TOLS	DRAWN G. UDOWICZENKO	DATE 26-08-09	SURFACE FINISH	WEIGHT (Kg)	THIS DRAWING AND ANY INFORMATION OR DESCRIPTIVE MATTER THEREIN IS COMMUNICATED IN CONFIDENCE AND IS THE COPYRIGHT PROPERTY OF EUROPEAN SAFETY SYSTEMS LTD. NEITHER THE WHOLE OR ANY EXTRACT MAY BE DISCLOSED, LOANED, COPIED OR USED FOR MANUFACTURING OR TENDERING PURPOSES WITHOUT THEIR WRITTEN CONSENT.	 EUROPEAN SAFETY SYSTEMS LTD IMPRESS HOUSE MANSELL ROAD ACTON LONDON W3 7QH WWW.E2S.COM	ALL DIMENSIONS IN MM IF IN DOUBT, ASK - DO NOT SCALE			A2
	CHECKED	DATE	MATERIAL							
STANDARDS	APPROVED	DATE	ALTERNATIVE MATERIAL		EUROPEAN SAFETY SYSTEMS LTD. AS PER LATEST DATE OF ISSUE SHOWN ABOVE		TITLE E2xCS112 COMBINED OUTLINE	SCALE 1:1	SHEET 1 OF 1	DRAWING NUMBER SK0123