

1) Introduction

The BExH120D Hootronic flameproof sounder meets the requirements of the ATEX directive 94/9/EC and the IECEx scheme. The sounder produces traditional warning signals and can be used in hazardous areas where potentially flammable atmospheres may be present. Five different first stage sounds can be selected by internal pin headers, and each one can be externally changed to a second or third stage sound (see *sound table on Page 4*). The Hootronic sounder can be used in Zone 1 and Zone 2 areas with gases in groups IIA, IIB and IIC and temperature Classifications of T1, T2, T3 and T4. For ambient temperatures over +55°C the gas groups are limited to IIA and IIB.

2) Marking

All units have a rating label, which carries the following important information:-

Unit Type No. BExH120D

Input Voltage: DC Units 24V
AC Units 230V or 115V

Code: Ex d IIC T4 for Ta -50°C to +55°C
Ex d IIB T4 for Ta -50°C to +70°C

Certificate No's KEMA 99ATEX6312
IECEx KEM 10.0003

Epsilon x:
Equipment Group
and Category:

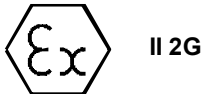

CE Marking:
Notified Body No.



“Warnings” DO NOT OPEN WHEN AN EXPLOSIVE
GAS ATMOSPHERE IS PRESENT

COVER BOLTS CLASS A4-80

USE HEAT RESISTING CABLES AND CABLE GLANDS
(Rated 110°C) AT AMB. TEMPERATURES OVER 40°C

Year of Construction /
Serial No. i.e. 10 / 1H12000001

3) Type Approval Standards

The sounder has EC Type Examination and IECEx certificates issued by KEMA and has been approved to the following standards:-

EN60079-0:2006 IEC60079-0:2004 (Ed4) General Requirements
EN60079-7:2003 IEC60079-7:2001 (Ed3) Increased Safety 'e'

4) Installation Requirements

The Hootronic sounder must be installed in accordance with the latest issues of the relevant parts of the EN60079 specifications or the equivalent IEC specifications – Selection, Installation and maintenance of electrical apparatus for use in potentially explosive atmospheres (other than mining applications or explosive processing and manufacture):-

EN60079-14:2008 Electrical Installations in Hazardous
IEC60079-14:2007 (Ed4) Areas (other than mines)
EN60079-10:2003 Classification of Hazardous Areas
IEC60079-10:2008 (Ed1)

The installation of the units must also be in accordance with any local codes that may apply and should only be carried out by a competent electrical engineer who has the necessary training.

5) Zones, Gas Group, Category and Temperature Classification

The BExH120D Hootronic sounder has been certified Ex d IIC T4 for Ta -50°C to +55°C and Ex d IIB T4 for Ta -50°C to +70°C. This means that the units can be installed in locations with the following conditions:-

Area Classification:

Zone 1	Explosive gas air mixture likely to occur in normal operation.
Zone 2	Explosive gas air mixture not likely to occur, and if it does, it will only exist for a short time.

Gas Groupings:

Group IIA	Propane
Group IIB	Ethylene
Group IIC (Up to +55°C only)	Hydrogen and Acetylene

Equipment Category: 2G

Temperature Classification:

T1	400°C
T2	300°C
T3	200°C
T4	135°C

Ambient Temperature Range:

-50°C to +55°C Gas Groups IIA, IIB and IIC
-50°C to +70°C Gas Group IIA and IIB

6) Sounder Location and Mounting

The location of the sounder should be made with due regard to the area over which the warning signal must be audible. The sounder should only be fixed to services that can carry the weight of the unit.

The sounder should be securely bolted to a suitable surface using the 7mm diameter boltholes in the stainless steel U shaped mounting bracket (see figure 1). The angle can then be adjusted in the direction that the sound is primarily required to cover. This can be achieved by loosening the two large bracket screws in the side of the unit, which allow adjustment in steps of 18°. On completion of the installation the two large bracket adjustment screws on the side of the unit must be fully tightened to ensure that the unit cannot move in service.

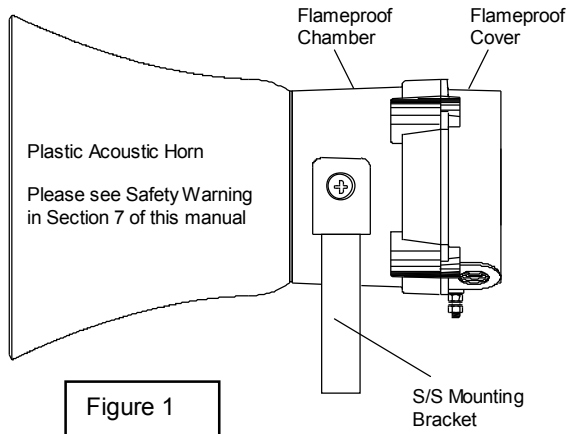

Figure 1

7) Safety Warning (Electrostatic Hazard)

The acoustic horn section is made of ABS Plastic, therefore to avoid a possible ELECTROSTATIC CHARGE the unit must only be cleaned with a damp cloth.

8) Access to the Flameproof Enclosure

In order to connect the electrical supply cables to the sounder it is necessary to remove the flameproof cover to gain access to the flameproof chamber. To achieve this remove the four M6 hexagon socket head screws (see figure 2) and withdraw the flameproof cover taking extreme care not to damage the flameproof joints in the process.

Note the four **M6 screws are Class A4-80 stainless steel and only screws of this category can be used on these sounders.** It is therefore important that these screws and their spring washers are kept in a safe place during installation.

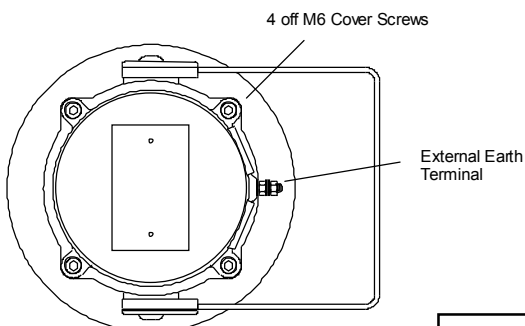

Figure 2

On completion of the cable wiring installation the flameproof joints should be inspected to ensure that they are clean and that they have not been damaged during installation. Also check that the earth bonding wire between the two casting

sections is secure and the 'O' ring seal is in place. When replacing the flameproof cover casting ensure that it is square with the flameproof chamber casting before inserting. Carefully push the cover in place allowing time for the air to be expelled. Only after the cover is fully in place should the four M6 Stainless Steel A4-80 cover bolts and their spring washer be inserted and tightened down. If the cover jams while it is being inserted, carefully remove it and try again. Never use the cover bolts to force the cover into position.

9) Power Supply Selection

It is important that a suitable power supply is used to run the sounder. The power supply selected must have the necessary capacity to provide the input current to all of the sounders connected to the system.

The following table shows the input current taken by the various sounder units:-

Unit Type	Input Voltage	Input Current	Max. I/P Volts
BExH120D	24V DC	400mA	30V
BExH120D	230V AC	90mA	253V
BExH120D	115V AC	180mA	126.5V

The above table also shows the maximum voltages at which the sounders can be operated.

10) Cable Selection

When selecting the cable size consideration must be given to the input current that each unit draws (see table above), the number of sounders on the line and the length of the cable runs. The cable size selected must have the necessary capacity to provide the input current to all of the sounders connected to the line.

SAFETY WARNING: If the BExH120D Hootronic sounder is used at high ambient temperatures, i.e. over +40°C, then the cable entry temperature may exceed +70°C and therefore suitable heat resisting cables must be used, with a rated service temperature of at least 110°C.

11) Earthing

Both AC and DC sounder units must be connected to a good quality earth. The units are provided with internal and external earthing terminals which are both located on the terminal chamber section of the unit (see figures 2 and 3).

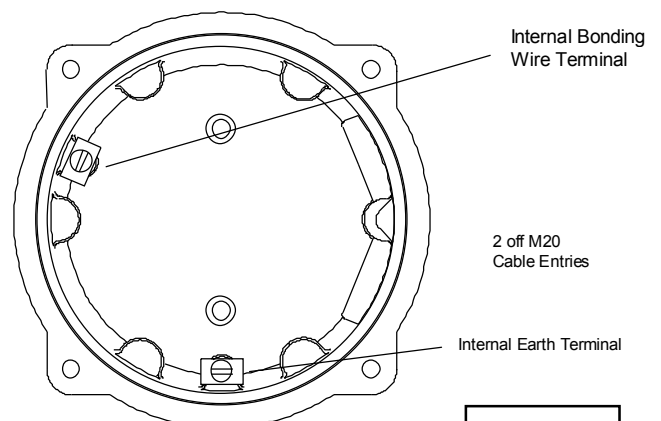

Figure 3

When using the internal earth terminal ensure that the stainless steel M4 flat washer is between the incoming earth wire and the enclosure.

When using the external earth terminal a cable crimp lug must be used. The cable lug should be located between the two M5 stainless steel flat washers. The M5 stainless steel spring washer must be fixed between the outer flat washer and the M5 stainless steel nut to ensure that the cable lug is secured against loosening and twisting.

The internal earth bonding wire ensures that a good quality earth is maintained between the flameproof chamber casting and the flameproof cover casting.

12) Cable Glands

The BExH120D Hootronic sounder has dual cable gland entries which have an M20 x1.5 entry thread as standard. Only cable glands approved for Ex 'd' applications can be used, which must be suitable for the type of cable being used and also meet the requirements of the Ex 'd' flameproof installation standard EN60079-14:2008 / IEC60079-14:2007.

SAFETY WARNING: If the BExH120D sounder is used at high ambient temperatures, i.e. over +40°C, then the cable entry temperature may exceed +70°C and therefore suitable heat resisting cable glands must be used, with a rated service temperature of at least 110°C.

If a high IP (Ingress Protection) rating is required then a suitable sealing washer must be fitted under the cable gland.

When only one cable entry is used the other one must be closed with an Ex 'd' flameproof blanking plug, which must be suitably approved for the installation requirements.

13) Cable Connections

The cable connections are made into the terminal blocks on the electronic pcb assembly located in the flameproof enclosure. See section 8 of this manual for access to the flameproof enclosure. On the AC units a two-way terminal block is provided for the live and neutral mains supply wires and a four way terminal block is provided for linking the Stop and the second and third stages, (see figure 5). On the DC units a five way terminal block is provided for +ve and -ve supply input and second and third stage and the Stop modes of operation, (see figure 4).

BExH120D DC Sounder

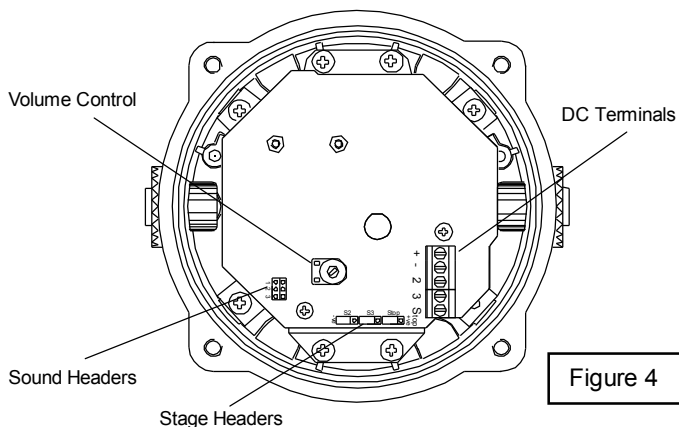

Figure 4

A single wire with a cross sectional area of up to 4mm² can be connected to each terminal way or if an input and output wire is required two 2.5mm² wires can be connected to each terminal way. When connecting wires to the terminals great care should be taken to dress the wire so that when the cover is inserted into the chamber the wires do not exert excess pressure on the terminal blocks. This is particularly important when using cables with large cross sectional areas such as 2.5mm² and above.

BExH120D AC Sounder

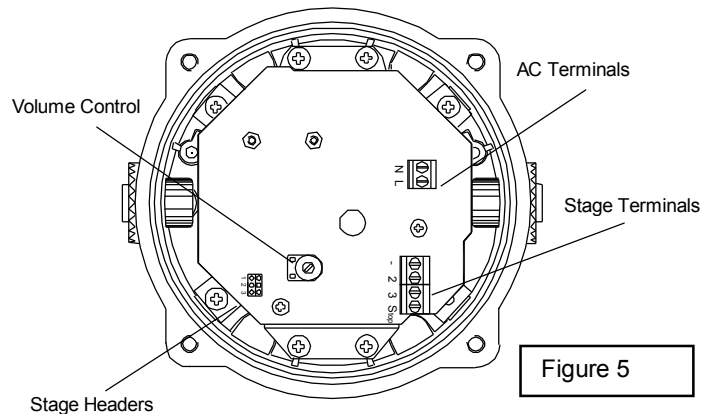

Figure 5

14) Sound Selection

The BExH120D Hootronic sounder has 5 different traditional sounds that can be selected for the first stage alarm. The sounders can then be switched to sound second and third stage alarm sounds. The sounds are selected by pin headers on the pcb for both DC and AC units. The sound table on page four shows the pin header positions for the 5 sounds and which sounds are available for the second and third stages.

The BExH120D Hootronic sounder has the facility to replicate the "tail off" traditionally associated with these sounds when generated by electro-mechanical devices. The switching is achieved using the "Stop" terminal (see section 15).

15) Stop and 2nd & 3rd Stage Alarm Sound Selection

The operation of the second and third stages is different for DC and AC units.

DC Units Second and Third Stage Sound Selection

The BExH120D Hootronic DC sounder has the facility to use either +ve or -ve switching to change the sound to the second and third stages. For -ve switching connect the two headers on the pcb to the left-hand (marked -ve) and centre pins. For +ve switching connect the headers to the right hand (marked +ve) and the centre pins. To change to the second stage sound, connect either a -ve or +ve supply line to terminal S2, depending on which switching mode is being used while maintaining the dc supply to the +ve and -ve terminals. Similarly for the third stage sound, connect a -ve or +ve supply line to terminal S3. The supply to the S3 terminal will automatically override a supply to the S2 terminal.

Stage Headers Set for –ve Switching

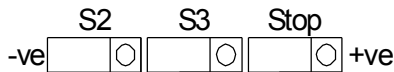

Stage Headers Set for +ve Switching

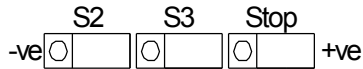

Stop Terminal

The user can remotely activate and deactivate the BExH120D Hootronic DC sounder by switching a connection from the “Stop” terminal to the –ve or +ve supply lines, depending on which switching mode is being used +ve or –ve (see above) whilst the unit is powered. To achieve the “tail off” sound at switch off the unit must remain powered.

Sound Selection Table

Stage 1	Discription	Stage 2	Stage 3	Header
Sound 1	Industrial Hooter	Sound 3	Sound 5	1 2 3
Sound 2	High Frequency Mechanical Siren	Sound 1	Sound 5	1 2 3
Sound 3	Medium Frequency Mechanical Siren	Sound 1	Sound 5	1 2 3
Sound 4	Electro Mechanical Buzzer	Sound 2	Sound 5	1 2 3
Sound 5	Mechanical Bell	Sound 1	Sound 2	1 2 3

AC Units Second and Third Stage Sound Selection

To select the second and third stage sounds on the BExH120D Hootronic AC sounder the Common (C) terminal on the four way terminal block on the pcb is connected to the S2 terminal for the second stage sound and the S3 terminal for the third stage sound.

Stop Terminal

The user can remotely activate and deactivate the BExH120D Hootronic AC sounder by switching a connection between the “Stop” terminal to the “C” terminal whilst the unit is powered. To achieve the “tail off” sound at switch off the unit must remain powered.

16) Volume Control

The BExH120D Hootronic sounder has a volume control to adjust the output level. To set the required output level, adjust the potentiometer on the pcb. For maximum output level the potentiometer should be set to the fully clockwise position.

17) End of Line Monitoring (DC Units)

On BExH120D Hootronic DC units, dc reverse line monitoring can be used if required. The DC unit has a blocking diode fitted in their supply input lines. An end of line monitoring diode or an end of line monitoring resistor can be connected across the +ve and –ve terminals. If an end of line resistor is used it must have a minimum resistance value of 3k3 ohms and a minimum wattage of 0.5 watts or a minimum resistance value of 500 ohms and a min. wattage of 2 watts.