

# L101 Xenon, L.E.D., Filament Lamp Beacon

The L101 is a compact, robust beacon ideal for all general signalling applications including fire, security and process control. Available with either a Xenon, L.E.D. or filament lamp light source.

**Part codes:**

[b] = Back box type:

- A: A100 type, M: Multi-purpose type
- S: Sonora type.
- Omit for standard L101 back box

[x] = Housing colour:

- G: Grey, R: Red, W: White

[y] = Lens colour:

- A: Amber, B: Blue, C: Clear,
- G: Green, O: Opal, R: Red, Y: Yellow

Note: LED version only available with Amber, Blue, Green, Red & Yellow.

Suffix part number with '-UL' for UL approved version (Xenon version only).

For Synchronised Xenon versions start part code with L101S.

**Features:**

- Back boxes available with and without mounting lugs
- Tropicalisation available on request
- Can be stacked to create multi-signal units.
- Can be combined with AlertAlarm & Sonora audible signals

**Approvals:**

- UL approved version available.
- GOST-R certificate: POCC GB.JB05.B02228



0786-CPD-20338

Multi-purpose type back box

A100 type back box

Sonora type back box

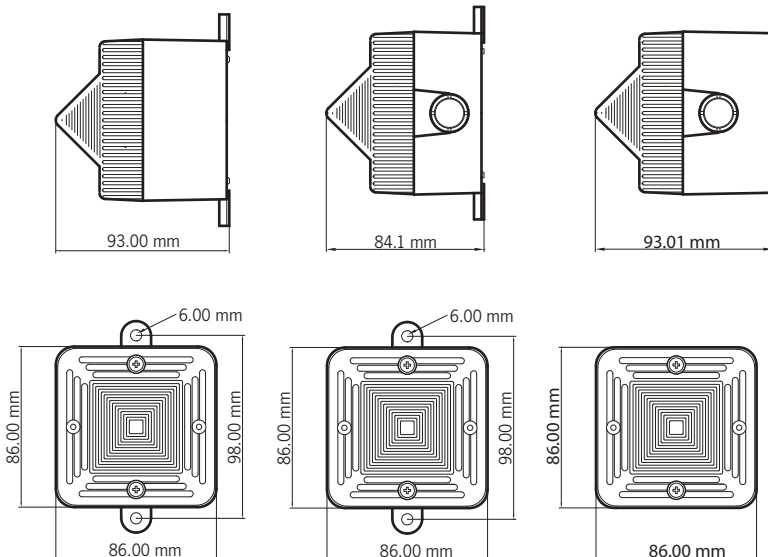

## L101 standard back box

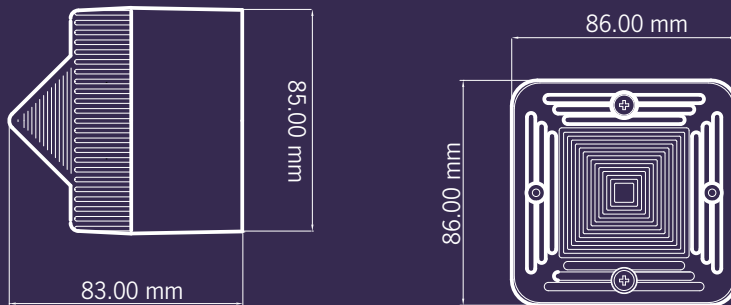
**Specification:****L101 - Xenon:**

Energy:	5 Joules (5Ws)
Flash rate:	1Hz (60 fpm)
Peak Candela:	86,935 cd
Effective Intensity cd:	200 cd*
Terminals:	0.5 to 4.0mm <sup>2</sup> cables.
Lens colours:	Amber, Blue, Clear, Green, Opal, Red, Yellow
Tube life :	Emissions are reduced to 70% after 8 million flashes
Synchronisation:	'Synch' version available providing full synchronisation on multi-beacon systems.

**L101L - L.E.D.:**

Light source:	High intensity L.E.D. array.
Options:	Steady or blinking (2Hz) mode.
Effective Intensity cd:	2 cd*
Terminals:	0.5 to 1.5mm <sup>2</sup> cables
Remote function:	Remote switching from steady to blinking mode.

**L101B - Filament Lamp:**

Light source:	Filament Bulb: 3 Watt (MES)
Options:	Steady or blinking (1.5Hz) mode.
Effective Intensity cd:	2 cd*
Terminals:	0.5 to 1.5mm <sup>2</sup> cables
Remote function:	Remote switching from steady to blinking mode.

**General:**

Ingress Protection:	IP56
Housing material:	UL94V0 & 5VA FR ABS
Housing colour:	RAL3000 Red, RAL7038 Grey and White
Lens material:	PC
Fixings:	Stainless Steel
Operating temp:	-25° to +55°C
Storage temp:	-40° to +70°C
Relative humidity:	90% at 20°C
Weight :	0.20kg

**Xenon Beacon:**

Version:	Voltage range:	Current mA:	Part Code:
12V dc/ac	10-14V	500mA/380mA	L101DC12[b][x]/[y]
24V dc/ac	20-28V	250mA/300mA	L101DC24[b][x]/[y]
48V dc/ac	42-54V	175mA/250mA	L101DC48[b][x]/[y]
115V ac 50/60Hz	+/-10%	70mA	L101AC115[b][x]/[y]
230V ac 50/60Hz	+/-10%	35mA	L101AC230[b][x]/[y]

**L.E.D. Beacon:**

Version:	Voltage range:	Current mA:	Part Code:
12V dc	10-14V dc	150mA	L101LDC12[b][x]/[y]
24V dc	20-28V dc	100mA	L101LDC24[b][x]/[y]
48V dc	42-54V dc	100mA	L101LDC48[b][x]/[y]
115V ac 50/60Hz	+/-10%	54mA	L101LAC115[b][x]/[y]
230V ac 50/60Hz	+/-10%	27mA	L101LAC230[b][x]/[y]

**Filament Lamp Beacon:**

Version:	Voltage range:	Current mA:	Part Code:
12V dc	10-14V dc	250mA	L101BDC12[b][x]/[y]
24V dc	20-28V dc	125mA	L101BDC24[b][x]/[y]
48V dc	42-54V dc	65mA	L101BDC48[b][x]/[y]
115V ac 50/60Hz	+/-10%	30mA	L101BAC115[b][x]/[y]
230V ac 50/60Hz	+/-10%	15mA	L101BAC230[b][x]/[y]



Available as the AL100 & SONFL1 alarm horn sounder & beacon combination unit - see the AlertAlight & Sonora ranges.