

AB112LDA Alarm Sounder & L.E.D Beacon

The AB112LDA combines a high output 119dB(A) alarm sounder with a powerful multi-function L.E.D. beacon.

The beacon and sounder can be operated from the same power source or controlled individually.

Features:

- Automatic synchronisation on multi-sounder system.
- Continuously rated.
- Stainless steel fixings.
- Unit can be mounted using external lugs or internal BESA compatible fixing positions.
- Duplicate cable terminations (in & out for daisy-chain installations).
- Tropicalisation available on request.
- Available with custom tone configurations and frequencies.
- 'Programmable' version available:
 - 45 alarm tones
 - 4 remotely selectable stages
 - Any tone can be assigned to any stage
 - User configurable continuous frequency tone

Approvals:

- Alarm sounder (A112N) VdS approved to EN54-3 (CPD 89/106/EEC).
- UKOOA/PFEER compliant alarm tones.

Part codes:

Version:	Part code:
24V dc	AB112LDADC24R/[y]
48V dc	AB112LDADC48R/[y]
115V ac	AB112LDAAC115R/[y]
230V ac	AB112LDAAC230R/[y]
[y] = Lens colour:	A: Amber B: Blue C: Clear G: Green R: Red Y: Yellow

Suffix part number with 'P' for programmable, 4 stage, 45 tone version.



0786-CPD-20257



G205121

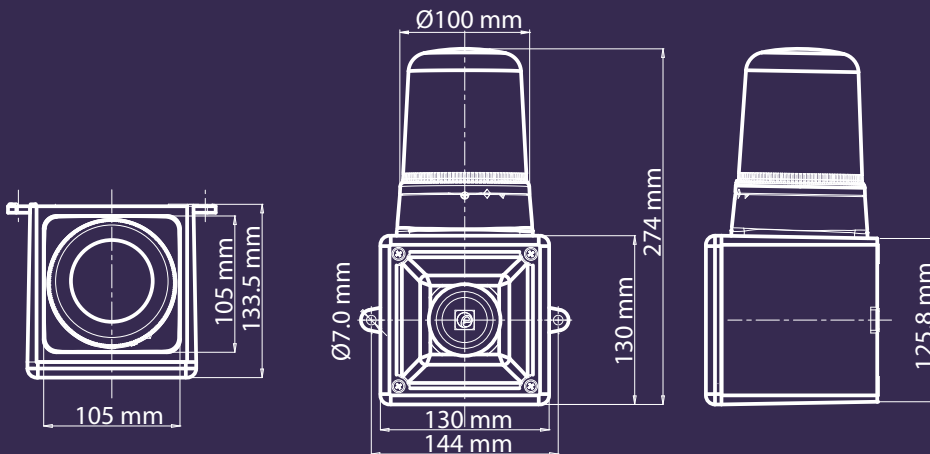

**Alarm sounder:**

Version:	Voltage range:	Current mA:
24V dc	10-30V dc	200mA*
48V dc	35-60V dc	120mA*
115V ac 50/60Hz	+/-10%	100mA
230V ac 50/60Hz	+/-10%	60mA

* current at nominal voltage on Tone 2

L.E.D. beacon:

Version:	Voltage range:	Current mA:
24V dc	10-50V dc	130mA*
48V dc	10-50V dc	130mA*
115V ac 50/60Hz	+/-10%	90mA
230V ac 50/60Hz	+/-10%	50mA

* current at 24V dc

Mode:	Stage 1	Stage2 [DC only]
1	All L.E.D.'s on	Alt. Side Flash 2Hz
2	Rotating: Slow1	Alt. Side Flash 2Hz
3	Single Flash 2Hz	Rotating: Fast 2
4	Rotating: Fast 1	Single Flash 2Hz
5	Rotating: Slow 2	Double Flash 1Hz
6	Double Flash 2Hz	Rotating: Fast 2
7	Rotating: Fast 2	Double Flash 2Hz
8	Double Flash 1Hz	Alt. Side Flash 2Hz
9	Alt. Side Flash 2Hz	Rotating: Fast 2

Specification:

Sounder:	
Maximum output:	119dB(A) @ 1 metre
Nominal output:	112dB(A) @ 1m +/- 3dB - Tone 2
No. of tones:	45 (UKOOA / PFEER compliant)
No. of stages:	3
Volume control:	Max. 112dB(A); Min.103dB(A) - Tone 2
Effective range:	125m @ 1KHz

Beacon:

Light source:	Array of 16 multi-function high power L.E.D.'s
Operating modes:	4 rotating configurations 4 flashing configurations Steady mode for indicator / status applications
Peak/Effective Candela:	19 cd*
No. of stages:	DC unit also features a remotely selectable 2nd stage flash pattern.
L.E.D / lens colours:	Amber, Blue, Clear (white L.E.D.s), Green, Red & Yellow

General:

Voltages DC:	24V dc (10-30V dc); 48V dc (35-60V dc)
Voltages AC:	115V ac; 230V ac
Ingress protection:	IP65
Housing material:	High impact UL94 V0 & 5VA FR ABS
Lens material:	UV stable PC UL94 V0 FR Bayonet lens fixing , anti-tamper locking screw.
Colour:	Red (RAL3000)
Cable entries:	2 x M20 clearance gland knockouts in side & back
Terminals:	0.5 to 4.0mm ² cables.
Operating temperature:	-25 to +55°C
Storage temperature:	-40 to +70°C
Relative humidity:	90% at 20°C.
Weight :	DC: 2.00kg AC:2.30kg

*Candela measurements representative of performance with amber lens at optimum voltage.

*SPL data +/-3dB(A). Measured at optimum voltage.

Tone table:

Stage 1	Frequency Description	dB @ 1m	Stage 2	Stage 3
Tone 1	340 Hz Continuous	107dB(A) @ 1m	Tone 2	Tone 5
Tone 2	800/1000Hz @ 0.25 sec Alternating	112dB(A) @ 1m	Tone 17	Tone 5
Tone 3	500/1200Hz @ 0.3Hz 0.5 sec Slow Whoop	113dB(A) @ 1m	Tone 2	Tone 5
Tone 4	800/1000Hz @ 1Hz Sweeping	113dB(A) @ 1m	Tone 6	Tone 5
Tone 5	2400Hz Continuous	119dB(A) @ 1m	Tone 3	Tone 20
Tone 6	2400/2900Hz @ 7Hz Sweeping	116dB(A) @ 1m	Tone 7	Tone 5
Tone 7	2400/2900Hz @ 1Hz Sweeping	116dB(A) @ 1m	Tone 10	Tone 5
Tone 8	500/1200/500Hz @ 0.3Hz Sweeping	113dB(A) @ 1m	Tone 2	Tone 5
Tone 9	1200/500Hz @ 1Hz - DIN / PFEER P.T.A.P.	113dB(A) @ 1m	Tone 15	Tone 2
Tone 10	2400/2900Hz @ 2Hz Alternating	119dB(A) @ 1m	Tone 7	Tone 5
Tone 11	1000Hz @ 1Hz Intermittent	112dB(A) @ 1m	Tone 2	Tone 5
Tone 12	800/1000Hz @ 0.875Hz Alternating	112dB(A) @ 1m	Tone 4	Tone 5
Tone 13	2400Hz @ 1Hz Intermittent	119dB(A) @ 1m	Tone 15	Tone 5
Tone 14	800Hz 0.25sec on, 1 sec off Intermittent	113dB(A) @ 1m	Tone 4	Tone 5
Tone 15	800Hz Continuous	113dB(A) @ 1m	Tone 2	Tone 5
Tone 16	660Hz 150mS on, 150mS off Intermittent	109dB(A) @ 1m	Tone 18	Tone 5
Tone 17	544Hz (100mS)/440Hz (400mS) - NF S 32-001	109dB(A) @ 1m	Tone 2	Tone 27
Tone 18	660Hz 1.8sec on, 1.8sec off Intermittent	109dB(A) @ 1m	Tone 2	Tone 5
Tone 19	1.4KHz-1.6KHz 1s, 1.6KHz-1.4KHz 0.5s -NFC48-265	114dB(A) @ 1m	Tone 2	Tone 5
Tone 20	660Hz Continuous	109dB(A) @ 1m	Tone 2	Tone 5
Tone 21	554Hz/440Hz @ 1Hz Alternating	109dB(A) @ 1m	Tone 2	Tone 5
Tone 22	544Hz @ 0.875 sec. Intermittent	109dB(A) @ 1m	Tone 2	Tone 5
Tone 23	800Hz @ 2Hz Intermittent	113dB(A) @ 1m	Tone 6	Tone 5
Tone 24	800/1000Hz @ 50Hz Sweeping	112dB(A) @ 1m	Tone 29	Tone 5
Tone 25	2400/2900Hz @ 50Hz Sweeping	116dB(A) @ 1m	Tone 29	Tone 5
Tone 26	Bell	108dB(A) @ 1m	Tone 2	Tone 15
Tone 27	554Hz Continuous	109dB(A) @ 1m	Tone 26	Tone 5
Tone 28	440Hz Continuous	106dB(A) @ 1m	Tone 2	Tone 5
Tone 29	800/1000Hz @ 7Hz Sweeping	112dB(A) @ 1m	Tone 7	Tone 5
Tone 30	300Hz Continuous	107dB(A) @ 1m	Tone 2	Tone 5
Tone 31	660/1200Hz @ 1Hz Sweeping	112dB(A) @ 1m	Tone 26	Tone 5
Tone 32	Two tone chime.	108dB(A) @ 1m	Tone 26	Tone 15
Tone 33	745Hz @ 1Hz Intermittent	109dB(A) @ 1m	Tone 2	Tone 5
Tone 34	1000 & 2000Hz @ 0.5 sec Alternating - Singapore	109dB(A) @ 1m	Tone 38	Tone 45
Tone 35	420Hz @ 0.625 sec Australian Alert	114dB(A) @ 1m	Tone 36	Tone 5
Tone 36	500-1200Hz 3.75sec /0.25sec. Australian Evac.	108dB(A) @ 1m	Tone 35	Tone 5
Tone 37	1000Hz Continuous - PFEER Toxic Gas	113dB(A) @ 1m	Tone 9	Tone 45
Tone 38	2000Hz Continuous	112dB(A) @ 1m	Tone 34	Tone 45
Tone 39	800Hz 0.25sec on, 1 sec off Intermittent	116dB(A) @ 1m	Tone 23	Tone 17
Tone 40	544Hz (100mS)/440Hz (400mS) - NF S 32-001	113dB(A) @ 1m	Tone 31	Tone 27
Tone 41	Motor Siren - slow rise to 1200 Hz	112dB(A) @ 1m	Tone 2	Tone 5
Tone 42	Motor Siren - slow rise to 800 Hz	114dB(A) @ 1m	Tone 2	Tone 5
Tone 43	1200 Hz Continuous	113dB(A) @ 1m	Tone 2	Tone 5
Tone 44	Motor Siren - slow rise to 2400 Hz	118dB(A) @ 1m	Tone 2	Tone 5
Tone 45	1KHz 1s on, 1s off Intermittent - PFEER Gen. Alarm	112dB(A) @ 1m	Tone 38	Tone 34

Country specific or custom tone configurations and alarm frequencies are available upon request.