

H100T Signalling Horn with Trumpet

The H100 series contains two variants of signalling horn, the H100T with trumpet horn and the compact H100B without trumpet horn. Both electronic signals authentically reproduce the alert sound of traditional electro-mechanical units but without any of the reliability issues.

Rated for continuous use the H100 series is a compact, high output signal suitable for a variety of installations. In addition to the 'buzzer' type sound the unit features a further two alarm sounds.

Features:

- Volume control
- Stainless steel fixings.

Part codes:

Version:	Part code:
10-30V ac/dc	H100T030G
40-260V ac/dc	H100T230G

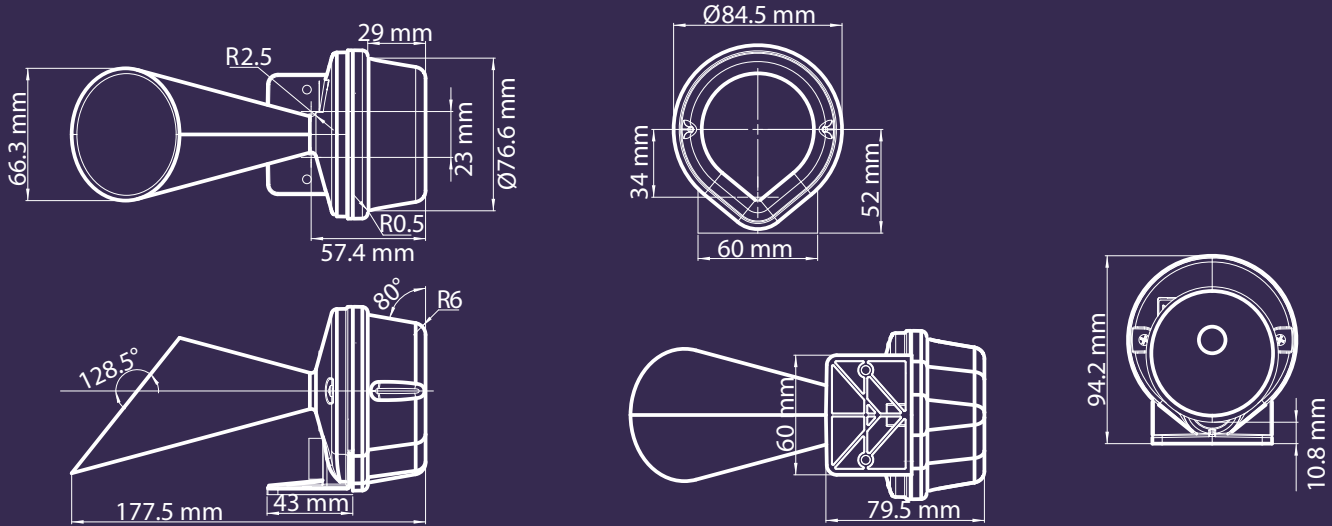

**Specification:**

No. of tones:	3
Output:	100 dB(A) @ 1m
Mounting:	Surface mount
Entries:	1 x 5-7mm push through grommet
Dimensions:	177.5 x 94.2mm
Ingress protection:	IP65
Housing material:	High impact ABS (UL94V0 & 5VA)
Terminals:	0.5 to 1.5mm ²
Operating temperature:	-25 to +50°C
Storage temperature:	-40 to +70°C
Relative humidity:	90% at 20°C.
Weight:	148g

*SPL data +/-3dB(A). Measured at optimum voltage.

Current consumption:

Version:	Voltage:	Current mA:
10-30V dc/ac	12V dc	10mA
10-30V dc/ac	24V dc	24mA
40-260V dc/ac	48V dc	15mA
10-30V dc/ac	12V ac 50/60Hz	30mA
10-30V dc/ac	24V ac 50Hz	62mA
40-260V dc/ac	48V ac 50/60Hz	25mA
40-260V dc/ac	115V dc	6mA
40-260V dc/ac	230V dc	3mA
40-260V dc/ac	115V ac 50/60Hz	19mA
40-260V dc/ac	230V ac 50/60Hz	10mA

Tone table:

Tone:	Description:	SPL (dB(A) @ 1m):
1	Buzzer Sound	100 dB(A)
2	1200/500Hz @ 1Hz - DIN	100 dB(A)
3	800/1000Hz & 7Hz	100 dB(A)