

# D1xC1X10F Alarm Horn & Xenon Strobe

**117dB(A) horn & 10 Joule Xenon.** The D1xC1X10F is a high output alarm horn sounder with re-entrant flare horn combined with a 1,000,000cd Xenon strobe beacon. The robust Type 4/4X, IP66 marine grade, corrosion proof aluminium enclosure ensures the D1xC1X10F is suitable for all Class I & II Division 1, Zone 1 & 20 explosion proof signaling applications. The DC version is approved for public mode fire alarm use (alarm horn) and private mode fire alarm use (strobe beacon).

The alarm horn & Xenon strobe may be powered from a common or dual supply allowing simultaneous or independent operation. Featuring 64 first stage/channel alarm sounds, the alarm tone frequencies for the first 2 stages are independently selectable. Each of the available 4 stage/channels can be remotely triggered e.g. via an external relay.

## Features

- Automatic synchronisation on multi-beacon & sounder systems.
- User selectable strobe flash rates - dual Xenon flash tubes
- Ratchet adjustable stainless steel 'U' bracket.
- High output alarm horn, up to 117dB(A)
- Xenon strobe - private mode fire alarm use
- Alarm horn - public mode fire alarm use
- 4 remotely selectable alarm stages/channels
- Positive or negative line stage/channel switching
- Choice of 64 alarm tone frequencies
- Compact form factor
- Robust corrosion proof aluminium enclosure
- Stainless steel fixings
- Triple cable entries
- Duplicate cable terminations

## Approvals

- UL File ref: E230764  
UL1203 Ed. 5  
CAN/CSA C22.2 No. 25-1966  
CSA C22.2 No. 30-M1986  
CSA C22.2 No. 205-12  
UL464 Ed. 9  
UL1638 Ed. 4

## Coding

### • A1: Gas version

NEC / CEC:

Class I Div 1 ABCD T5/T6 Ta -40°C to +55/+50°C

Class I Div 2 ABCD T5/T6 Ta -40°C to +55/+50°C

Class I Zone 1, 2 IIC T5/T6 Ta -40°C to +55/+50°C

### • D1: Dust version

NEC / CEC:

Class II Div 1 FG T4/T4A Ta -40°C to +55/+40°C

Class II Div 2 FG T4/T4A Ta -40°C to +55/+40°C

Class III Div 1 & 2

Zone 20, 21, 22 IIIB T4/T4A Ta -40°C to +55/+40°C



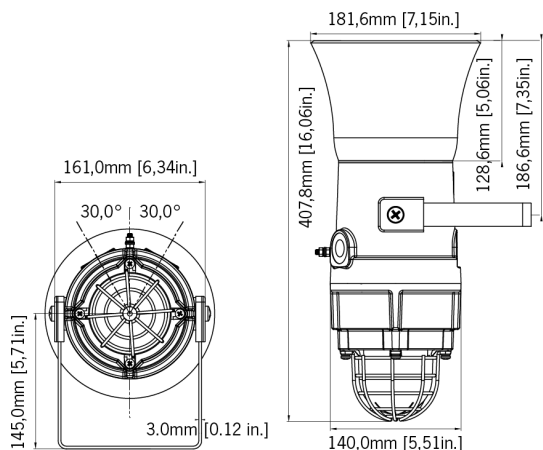

## Specification

### Alarm Horn:

Maximum output:	117dB(A) @ 1 metre [108dB(A) @ 10ft/3m]
Nominal output:	113dB(A) @ 1m +/- 3dB - Tone 2 [104dB(A) @ 10ft/3m]
No. of tones:	64 (UKOOA / PFEER compliant)
No. of stages:	4
Volume control:	Adjustable -12dB(A)
Effective range:	125m/410ft @ 1KHz
Supply Voltages:	24Vdc; 115Vac; 230Vac
Stage switching:	DC units: negative or positive AC units: common supply line

### Strobe Beacon:

Energy:	10 Joules (10Ws)
Flash rates:	Option 1: 1Hz (60 fpm) Option 2: 1.5Hz (90 fpm) Option 3: Double Strike
Peak Candela:	1,000,000 cd - calculated from energy (J)
Effective Intensity:	500 cd - calculated from energy (J)
Peak Candela:	85,544 cd* - measured ref. to I.E.S.
Effective Intensity:	260 cd* - measured ref. to I.E.S.
Lens colours:	Amber, Blue, Clear, Green, Magenta, Red & Yellow
Tube life:	Emissions are reduced to 70% after 8 million flashes

### General:

Ingress protection:	EN60529: IP66 UL50E / NEMA250: 4 / 4X / 3R / 13
Enclosure material:	Marine grade aluminium LM6- copper free Chromated & powder coated - corrosion proof
Colour:	Red (RAL3000), Grey (RAL7038)
Cable entries:	1 x 1/2"NPT & 2 x M20 x 1.5mm 1 x 1/2"NPT & 2 x 1/2"NPT 1 x 1/2"NPT & 2 x 3/4"NPT
Terminals:	0.5 - 2.5mm <sup>2</sup> (20-14 AWG)
Grounding stud:	M5
Operating temp:	24Vdc & 115Vac: -40° to +70°C [-40° to +158°F] 230Vac: -40° to +55°C [-40° to +131°F]
Storage temp:	-50° to +70°C [-58° to +158°F]
Relative humidity:	90% at 20°C [68°F]
Weight:	5.2kg/11.4lbs

## Part Codes

Version:	Part code:	
Product type:	D1xC1X10	
Horn type:	F	Flare reentrant horn
Voltage:	DC024	20-28V dc
	AC115	110-120V ac
	AC230	220-240V ac
Cable Entry Type: [e]	A	1 x 1/2"NPT & 2 x M20 x 1.5mm
	B	1 x 1/2"NPT & 2 x 1/2"NPT
	C	1 x 1/2"NPT & 2 x 3/4"NPT
Adaptor/Stopping plug material: [m]	B	Brass
	N	Nickel Plated
	S	Stainless Steel
Bracket material: [s]	1	A2 304 Stainless Steel
	2	A4 316 Stainless Steel
Product version: [v]	A1	Gas environments Class I/Zone1
	D1	Dust environments Class II/Zone 20
Enclosure colour: [x]	G	Grey RAL7038
	R	Red RAL3000
Lens colour: [y]	A, B, C, G	Amber, Blue, Clear, Green
	M, R, Y	Magenta, Red, Yellow
Example:	D1xC1X10FAC230 [e][m][s][v][x][y] D1xC1X10FAC230AB1A1R/A	

## Ratings:

A1:	Gas version
NEC / CEC:	Class I Div 1 ABCD T5/T6 Ta -40°C to +55/+50°C
	Class I Div 2 ABCD T5/T6 Ta -40°C to +55/+50°C
NEC:	Class I Zone 1, 2 IIC T5/T6 Ta -40°C to +55/+50°C
D1:	Dust version
NEC / CEC:	Class II Div 1 FG T4/T4A Ta -40°C to +55/+40°C
	Class II Div 2 FG T4/T4A Ta -40°C to +55/+40°C
	Class III Div 1&2
NEC:	Zone 20, 21, 22 IIIB T4/T4A Ta -40°C to +55/+40°C

## Current Consumption

Voltage:	Range:	Alarm Horn	Xenon Strobe	Combined
24V dc	20-28Vdc	217mA	673mA	890mA
115V ac	110-120Vac 50/60Hz	76mA	247mA	323mA
230V ac	220-240Vac 50/60Hz	53mA	120mA	173mA

## Tone table

S 1	Description	S 2	S 3	S 4	S 1	Description	S 2	S 3	S 4
T1	1000 Continuous PFEER Toxic Gas	Any	T2	T44	T33	800 (0.25s on, 1.00s off) Intermittent	Any	T24	T8
T2	1200/500 @ 1Hz Sweeping DIN/PFEER P.T.A.P.	Any	T3	T44	T34	800 @ 2Hz (0.25s on, 0.25s off) IMO code 3.a ...	Any	T24	T8
T3	1000 @ 0.5Hz (1s on, 1s off) Intermittent PFE...	Any	T2	T44	T35	1000 @ 1Hz (0.50s on, 0.50s off) Intermittent	Any	T24	T8
T4	1.4KH-1.6KHz 1s, 1.6KHz-1.4KHz 0.5s NF C 48-265	Any	T24	T1	T36	2400 @ 1Hz (0.50s on, 0.50s off) Intermittent	Any	T24	T8
T5	544(100mS)/440 (400mS) NF S 32-001	Any	T19	T1	T37	2900 @ 5Hz (0.10s on, 0.10s off) Intermittent	Any	T24	T8
T6	1500/500 - (0.5s on , 0.5s off) x3 + 1s gap A...	Any	T44	T1	T38	363/518 @ 1Hz (0.50s/0.50s) Alternating	Any	T8	T19
T7	500-1500Hz Sweeping 2 sec on 1 sec off AS4428	Any	T44	T1	T39	450/500 @ 2Hz (0.25s/0.25s) Alternating	Any	T8	T19
T8	500/1200Hz @ 0.26Hz(3.3s on, 0.5s off) NEN 2575	Any	T24	T35	T40	554/440 @ 1Hz (0.50s/0.50s) Alternating	Any	T24	T19
T9	1000 (1s on, 1s off)x7 + (7s on, 1s off) IMO ...	Any	T34	T1	T41	554/440 @ 0.65Hz (0.76s/0.76s) Alternating	Any	T8	T19
T10	1000 (1s on, 1s off)x7 + (7s on, 1s off) IMO ...	Any	T34	T1	T42	561/760 @ 0.83Hz (0.60s/0.60s) Alternating	Any	T8	T19
T11	420(0.5s on, 0.5s off)x3 + 1s gap ISO 8201 Te...	Any	T1	T8	T43	780/600 @ 0.96Hz (0.52s/0.52s) Alternating	Any	T8	T19
T12	1000(0.5s on, 0.5s off)x3 + 1s gap ISO 8201 T...	Any	T1	T8	T44	800/1000 @ 2Hz (0.25s/0.25s) Alternating	Any	T24	T19
T13	422/775 (0.85 on, 0.5 off) x3 + 1s gap NFPA T...	Any	T1	T8	T45	970/800 @ 2Hz (0.25s/0.25s) Alternating	Any	T8	T19
T14	1000/2000 @ 1Hz - Singapore	Any	T3	T35	T46	800/1000 @ 0.875Hz (0.57s/0.57s) Alternating	Any	T24	T19
T15	300 Continuous	Any	T24	T35	T47	2400/2900 @ 2Hz (0.25s/0.25s) Alternating	Any	T24	T19
T16	440 Continuous	Any	T24	T35	T48	500/1200 @ 0.3Hz (1.67s/1.67s) Sweeping	Any	T24	T12
T17	470 Continuous	Any	T24	T35	T49	560/1055 @ 0.18Hz (2.73s/2.73s) Sweeping	Any	T24	T12
T18	500 Continuous IMO code 2 (Low)	Any	T24	T35	T50	560/1055 @ 3.3Hz (0.15s/0.15s) Sweeping	Any	T24	T12
T19	554 Continuous	Any	T24	T35	T51	600/1250 @ 0.125Hz (4s/4s) Sweeping	Any	T24	T12
T20	660 Continuous	Any	T24	T35	T52	660/1200 @ 1Hz (0.50s/0.50s) Sweeping	Any	T24	T12
T21	800 Continuous IMO code 2 (High)	Any	T24	T35	T53	800/1000 @ 1Hz (0.50s/0.50s) Sweeping	Any	T24	T12
T22	1200 Continuous	Any	T24	T35	T54	800/1000 @ 7Hz (0.07s/0.07s) Sweeping	Any	T24	T12
T23	2000 Continuous	Any	T3	T35	T55	800/1000 @ 50Hz (0.01s/0.01s) Sweeping	Any	T24	T12
T24	2400 Continuous	Any	T20	T35	T56	2400/2900 @ 7Hz (0.07s/0.07s) Sweeping	Any	T24	T12
T25	440 @ 0.83Hz (0.60s on, 0.60s off) Intermittent	Any	T44	T8	T57	2400/2900 @ 1Hz (0.50s/0.50s) Sweeping	Any	T24	T12
T26	470 @ 0.9Hz (0.55s on, 0.55s off) Intermittent	Any	T44	T8	T58	2400/2900 @ 50Hz (0.01s/0.01s) Sweeping	Any	T24	T12
T27	470 @ 5Hz (0.10s on, 0.10s off) Intermittent	Any	T44	T8	T59	2500/3000 @ 2Hz (0.25s/0.25s) Sweeping	Any	T24	T12
T28	544 @ 1.14Hz (0.43s on, 0.44s off) Intermittent	Any	T24	T8	T60	2500/3000 @ 7.7Hz (0.65s/0.65s) Sweeping	Any	T24	T12
T29	655 @ 0.875Hz (0.57s on, 0.57s off) Intermittent	Any	T44	T8	T61	800Hz Motor Siren	Any	T24	T12
T30	660 @ 0.28Hz (1.80s on, 1.80s off) Intermittent	Any	T24	T8	T62	1200Hz Motor Siren	Any	T24	T12
T31	660 @ 3.3Hz (0.15s on, 0.15s off) Intermittent	Any	T24	T8	T63	2400Hz Motor Siren	Any	T24	T12
T32	745 @ 1Hz (0.50s on, 0.50s off) Intermittent	Any	T24	T8	T64	Simulated Bell	Any	T21	T12