

Applications and users that have traditionally demanded conventional electromechanical hooters, sirens, buzzers and bells can now choose the next generation alternative. The technology used in the Hootronic range features the latest in amplifier and digital to analogue conversion technology.

The E2S Hootronic series of products faithfully reproduce the sounds made by traditional electro-mechanical signalling devices but in a modern, reliable and cost effective way. With output levels of up to 121dB(A) at 1 metre the Hootronic also surpasses the performance and effectiveness of its traditional counterpart. Unlike the traditional electro-mechanical devices the Hootronic range is continuously rated, requires zero maintenance and signal quality and performance will not degrade with age.

The lightweight, durable housings are manufactured from impact and fire resistant UL94V0 & 5VA ABS. The unit can also be supplied as combined unit (the HAL121 version) with either a 5 Joule Xenon, L.E.D or filament bulb beacon in a choice of up to 7 lens colours.

### Specifications:

- Nominal output : 121dB(A) @ 1m +/-3dB
- 3 stage alarm option
- Volume control
- 300m effective range
- Voltages : 24vdc; 115vac; 230vac
- HA121: IP55 (up to IP66 dust protected & watertight with WR kit)
- HAL121: IP55 (up to IP56 with WR kit)
- Enclosure material : UL94V0 & 5VA rated FR ABS
- Colour available : Red (RAL3000), Grey (RAL7035)
- Operating temperature : -25 to +55°C
- Storage temperature : -40 to +70°C
- Relative humidity : 90% at 20°C
- Weight HA121: DC: 2.10Kg AC: 2.70Kg  
 HAL121: DC: 2.30Kg AC: 2.90Kg
- HAL121L: Xenon: 5 Joule @ 1Hz (5 Ws) (60 FPM)
- HAL121L: L.E.D: 8 x L.E.D array (Steady or flashing @ 2Hz).
- HAL121B: Bulb: Filament 3 watt (Steady or flashing @ 1.5Hz).



HA121: Hootronic Alarm Horn



HAL121: Hootronic Alarm Horn combined with either Xenon, filament bulb or L.E.D beacon.

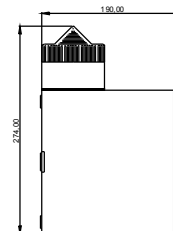
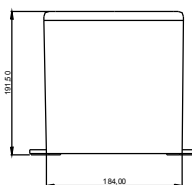
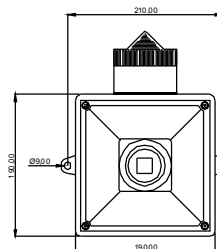
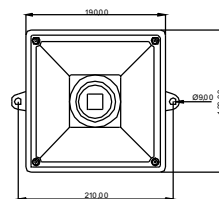

All dimensions are in millimetres.

### NOTE:

- If applicable please review accompanying installation instructions for details regarding the xenon, bulb or L.E.D beacon.
- Cables for connecting the sounder to the beacon are supplied with the product.



>121dB(A)@1m.

Voltage range and current consumption for the HA121 Hootronic Alarm Horn:

Voltage:	24vdc	115vac	230vac
		50/60Hz	50/60Hz
Range:	+/-25%	+/-10%	+/-10%
Current:	375mA	160mA	75mA

Voltage range and current consumption for the HAL121 Hootronic Alarm with 5J Xenon:

Voltage:	24vdc	115vac	230vac
		50/60Hz	50/60Hz
Range:	+/-25%	+/-10%	+/-10%
Current:	645mA	270mA	130mA

Voltage range and current consumption for the HAL121L Hootronic Alarm with L.E.D beacon:

Voltage:	24vdc	115vac	230vac
		50/60Hz	50/60Hz
Range:	+/-25%	+/-10%	+/-10%
Current:	475mA	204mA	102mA

Voltage range and current consumption for the HAL121L Hootronic Alarm with Bulb beacon:

Voltage:	24vdc	115vac	230vac
		50/60Hz	50/60Hz
Range:	+/-25%	+/-10%	+/-10%
Current:	500mA	190mA	90mA

## Mounting and cabling instructions:

The unit can be mounted with either the external lugs or by fixing through the back of the housing. For internal fixing the HA121 has BESA compatible fixing positions marked.

The HA121 is shipped with one M20 clearance cable entry hole populated with an IP55 stopping plug. For installations requiring the cable entry to be through the rear of the unit a M20 clearance 'knockout' is located in the centre of the back wall of the housing. The terminals in the HA121 and HAL121 products will accept from 0.5mm<sup>2</sup> to 4.0mm<sup>2</sup> stranded or single core cables.

## DC units:

DC power supply connections should be made to the + and - terminals.

To remotely switch the second and third stage sounds cable into the terminals marked 'S2' and 'S3' respectively. To activate the second and third stage sounds switch 'S2' or 'S3' to the negative supply whilst the unit is powered (see Fig.1). Stage 2 overrides stage 1 and stage 3 overrides stage 2.

The Hootronic sounder has the facility to replicate the 'tail off' traditionally associated with these tone when generated by electro-mechanical devices. The switching is achieved by cabling into the terminal marked STOP. The user can remotely activate and de-activate the sounder by switching the connection between the STOP wire and the negative supply line whilst the unit is powered. To achieve the 'tail off' sound at switch off the unit must remain powered.

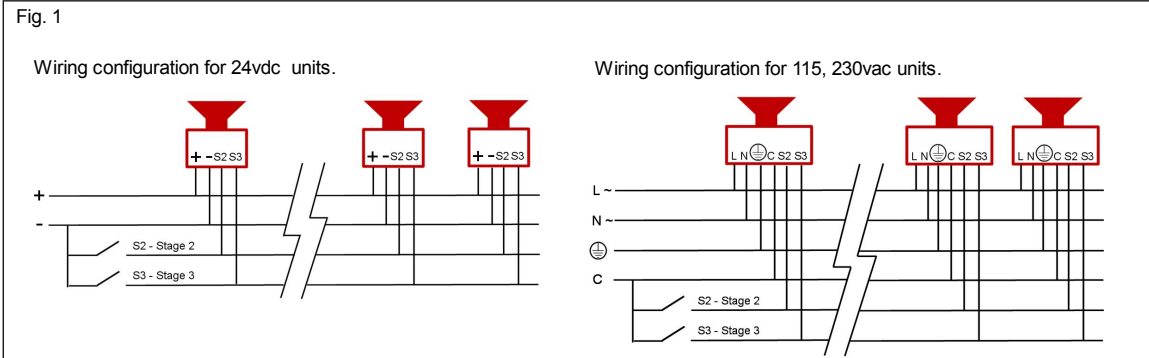

## AC units:

AC power supply connections should be made to the L, N and E terminals.

To remotely switch the second and third stage sounds cable into the terminals marked 'C/-', 'S2' and 'S3' respectively. To activate the second and third stage sounds switch 'S2' or 'S3' to the 'C/-' cable whilst the unit is powered (see Fig.1). Stage 2 overrides stage 1 and stage 3 overrides stage 2.

The Hootronic sounder has the facility to replicate the 'tail off' traditionally associated with these tone when generated by electro-mechanical devices. The switching is achieved by cabling into the terminals marked STOP and 'C/-'. The user can remotely activate and de-activate the sounder by switching the connection between STOP and the 'C/-' cables whilst the unit is powered. To achieve the 'tail off' sound at switch off the unit must remain powered.

## Tone Selection:

The Hootronic HA121, HAL 121, HAL121L and HAL 121B have 5 user selectable 'traditional' sounds:

- Tone 1 : **Industrial Hooter**
- Tone 2 : **High Frequency Mechanical Siren**
- Tone 3 : **Medium Frequency Mechanical Siren**
- Tone 4 : **Electro Mechanical Buzzer**
- Tone 5 : **Mechanical Bell**

Each of these sounds has two additional, remotely selectable, alarm stages as shown in the table below (see Fig 2.). The first stage tone is selected by means of the pin headers marked 1,2,3 on the PCBA. Use the supplied jumper connectors to select the required tone by following the diagrams in the table below. See 'Mounting and cabling instructions' for details of how to activate the second and third stages.

Fig. 2

Stage1 tone	Alarm Description	Stage2 (S2)	Stage3 (S3)	Header
Tone 1	Industrial Hooter	Tone 3	Tone 5	3 ●● 2 ●● 1 ●●
Tone 2	High Frequency Mechanical Siren	Tone 1	Tone 5	3 ●● 2 ●● 1 ●●
Tone 3	Medium Frequency Mechanical Siren	Tone 1	Tone 5	3 ●● 2 ●● 1 ●●
Tone 4	Electro Mechanical Buzzer	Tone 1	Tone 5	3 ●● 2 ●● 1 ●●
Tone 5	Mechanical Bell	Tone 1	Tone 2	3 ●● 2 ●● 1 ●●



### ATTENTION

- Disconnect from power source to prevent electrical shock before installing and servicing
- Couper l'alimentation pour empêcher tout choc électrique avant d'effectuer des travaux d'installation et d'entretien.
- Vor der Installation und Wartung von der Spannungsquelle abnehmen, um elektrische Schläge zu vermeiden
- Prima dell'installazione e della manutenzione spegnere l'alimentazione elettrica per evitare scosse elettriche.
- Desconecte la alimentación para evitar descargas eléctricas antes de la instalación y mantenimiento
- Antes de instalar ou de fazer a manutenção desligue sempre da alimentação elétrica para evitar choques elétricos.
- Strømmen skal afbrydes ved installering og eftersyn for at undgå elektrisk stød.
- Los koppel van de elektrische voeding om elektrische schok vóór installatie en onderhoud te voorkomen.
- Før monteringen eller vedlikehold, må spenningen koples fra for å unngå strømstøt.
- Bryt strømmen innan installation och underhåll för att förhindra elektriska stötar stötar.

# Hootronic wiring configuration with «Tail-Off» function

**AC** power supply connections should be made to the "L", "N" and "E" terminals. To remotely switch the second and third stage sounds, cable into the terminals marked "C", "S2" and "S3" respectively. To activate the second and third stage sounds switch "S2" or "S3" to the "C" cable whilst the unit is powered (see Fig.1 on previous page). Stage 2 overrides stage 1 and stage 3 overrides stage 2.

The Hootronic sounder has the facility to replicate the "tail-off" traditionally associated with these tones, when generated by electro-mechanical devices. The switching is achieved by cabling into the terminals marked "STOP" and "C". The user can remotely activate and de-activate the sounder by switching the connection between "STOP" and the "C" cables whilst the unit is powered. To achieve the "tail-off" sound at switch off, the unit must remain powered.

In other words, linking between "Stop" and "C", silence the sounder. Braking the link between "Stop" and "C", activates the sounder.

**DC** power supply connections should be made to the "+" and "-" terminals. To remotely switch the second and third stage sounds, cable into the terminals marked "S2" and "S3" respectively. To activate the second and third stage sounds switch "S2" or "S3" to the negative supply whilst the unit is powered (see Fig.1 on previous page). Stage 2 overrides stage 1 and stage 3 overrides stage 2.

The Hootronic sounder has the facility to replicate the "tail-off" traditionally associated with these tones, when generated by electro-mechanical devices. The switching is achieved by cabling into the terminal marked "STOP" and "-". The user can remotely activate and de-activate the sounder by switching the connection between the "STOP" wire and the negative supply line ("-") whilst the unit is powered. To achieve the "tail-off" sound at switch off, the unit must remain powered.

In other words, linking between "Stop" and "-", silence the sounder. Braking the link between "Stop" and "-", activates the sounder.

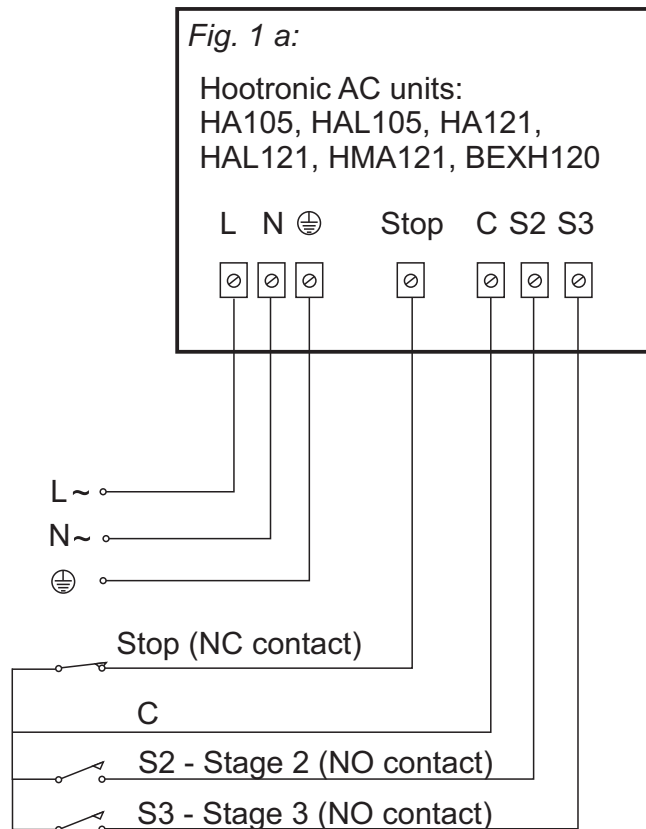

*P.s: For easy operation*

*In most installations, people are only interested in one of the several selectable sounds. In that case, select the desired sound, and ignore the "S2" and "S3" terminals.*

*Connect the power cables to a steady power supply, and activate the sounder via the "Stop" and "C/-" terminals only, by connecting through a simple «potential free» switch or relay.*

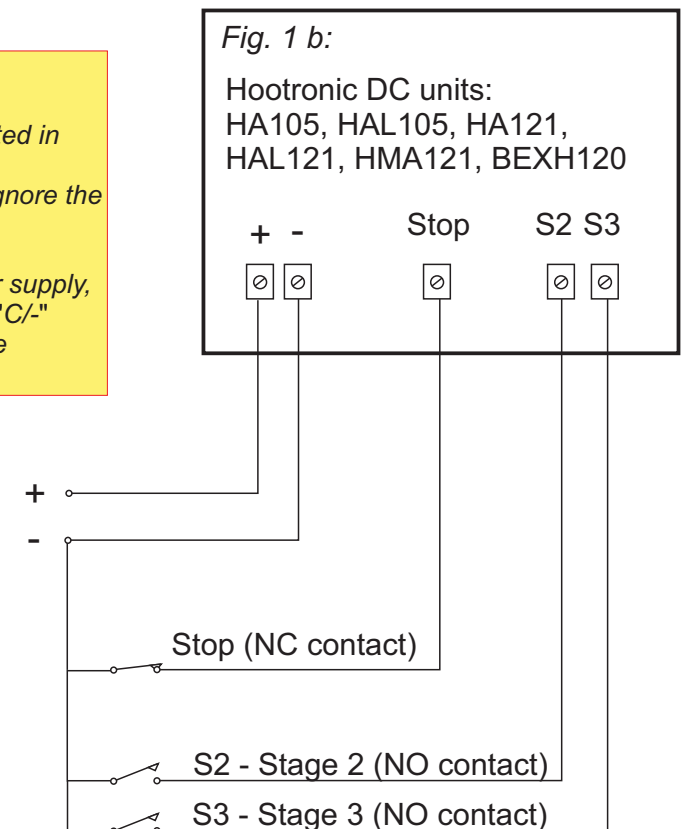

12, 24, 48vdc/vac

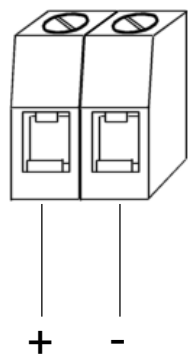

115, 230vac

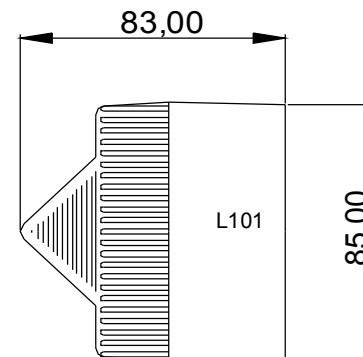
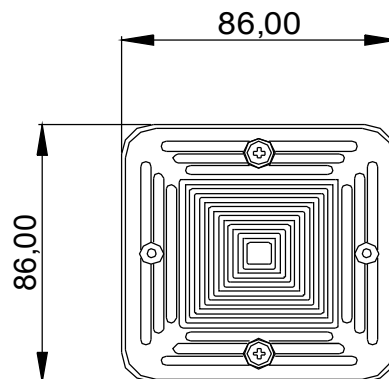
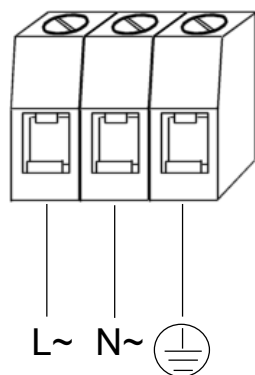

Voltage :	12vdc	24vdc	48vdc	12vac	24vac	48vac	115vac	230vac
				50/60Hz	50/60Hz	50/60Hz	50/60Hz	50/60Hz
Voltage range :	10-14v	20-28v	42-54v	+/-10%	+/-10%	+/-10%	+/-10%	+/-10%
Current mA :	500mA	250mA	175mA	380mA	300mA	300mA	70mA	35mA



- Disconnect from power source to prevent electrical shock before installing and servicing
- Couper l'alimentation pour empêcher tout choc électrique avant d'effectuer des travaux d'installation et d'entretien.
- Vor der Installation und Wartung von der Spannungsquelle abnehmen, um elektrische Schläge zu vermeiden.
- Prima dell'installazione e della manutenzione spegnere l'alimentazione elettrica per evitare scosse elettriche.
- Desconecte la alimentación para evitar descargas eléctricas antes de la instalación y mantenimiento
- Antes de instalar ou de fazer a manutenção desligue sempre da alimentação eléctrica para evitar choques eléctricos.
- Strømmen skal afbrydes ved installering og eftersyn for at undgå elektrisk stød.
- Loskoppelen van de elektrische voeding om elektrische schok vóór installatie en onderhoud te voorkomen.
- Før monterning eller vedlikehold, må spenningen koples fra for å unngå strømstøt.
- Bryt strømmen innan installation och underhåll för att förhindra elektriska stötår stötar.

AL100



AL105N



AL112



AL121

