

1 STA BEACON STACK WITH ALARM SOUNDER

STA2/STA3/STA4
 IP Rating: 3R/13
 Temp: -40°C to +70°C
 CE / UKCA Marked & UL Listed



Mountings
 Multiple mounting lugs with holes suitable for up to M6 fixings.

2.5mm² terminals
 Cable entry: M20 cable entry

Complete Unit Order code	Description
STA2DC024AA0A1[x]	Junction box & SONF1, 2 x Beacons - DC
STA2AC115AA0A1[x]	Junction box & SONF1, 2 x Beacons - AC
STA2AC230AA0A1[x]	Junction box & SONF1, 2 x Beacons - AC
STA3DC024AA0A1[x]	Junction box & SONF1, 3 x Beacons - DC
STA3AC115AA0A1[x]	Junction box & SONF1, 3 x Beacons - AC
STA3AC230AA0A1[x]	Junction box & SONF1, 3 x Beacons - AC
STA4DC024AA0A1[x]	Junction box & SONF1, 4 x Beacons - DC
STA4AC115AA0A1[x]	Junction box & SONF1, 4 x Beacons - AC
STA4AC230AA0A1[x]	Junction box & SONF1, 4 x Beacons - AC

Component Unit Code	Type	Voltage
ST-L101XDC012A1[y]	Xenon	12V DC
ST-L101XDC024A1[y]	Xenon	24V DC
ST-L101XAC115A1[y]	Xenon	115V AC
ST-L101XAC230A1[y]	Xenon	230V AC
ST-L101HDC012A1[y]	LED	12V DC
ST-L101HDC024A1[y]	LED	24V DC
ST-L101HAC230A1[y]	LED	115/230V AC

[y] = Lens Colour
 A = Amber; B = Blue; C = Clear; G = Green;
 M = Magenta; R = Red; Y = Yellow

[x] = Housing colour
 R = Red; G = Grey; W = White

- ⚠ ATTENTION : Installation must be carried out by an electrician in compliance with the latest codes and regulations.
- ⚠ ATTENTION : Disconnect from power source before installation or service to prevent electric shock.
- ⚠ ATTENTION : On strobe beacons allow a minimum of 2 minutes for hazardous high voltage to discharge from unit.
- ⚠ ATTENTION : Lens on unit will be hot allow to cool prior to removal.
- ⚠ ATTENTION : Please check factory settings and ensure the correct alarm tone and flash patterns are selected for your country or application.

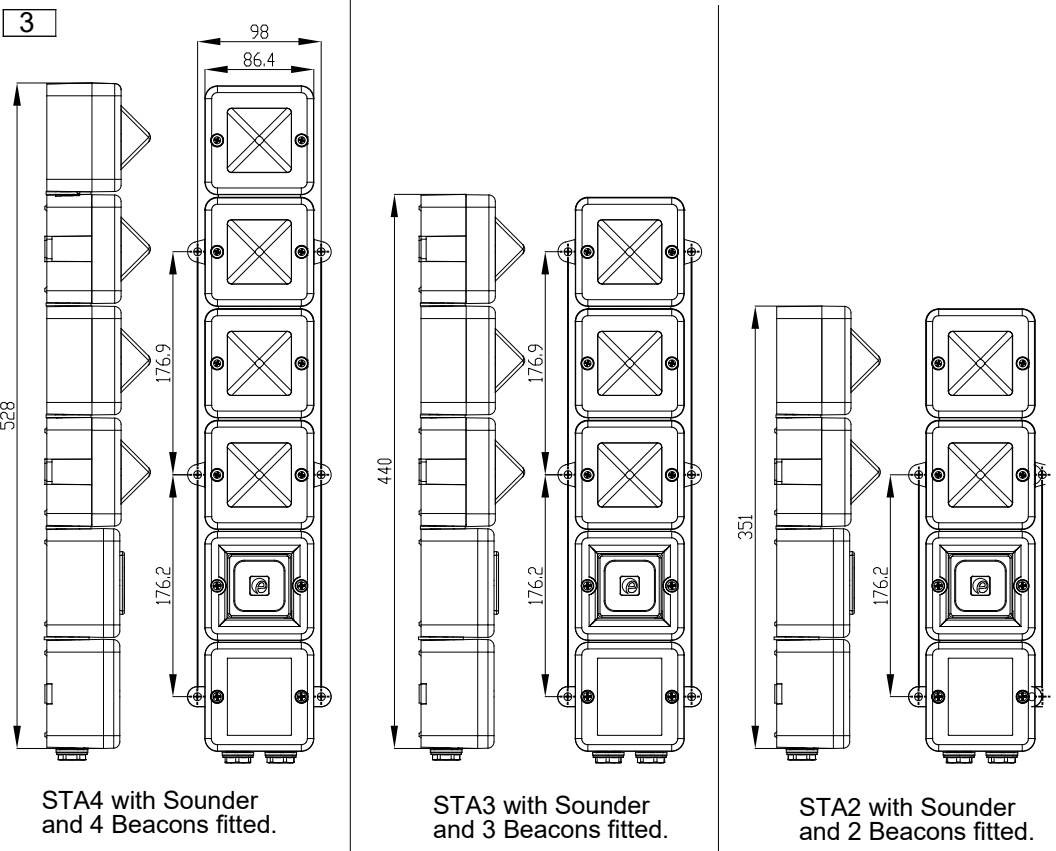

STA4 with Sounder and 4 Beacons fitted.

STA3 with Sounder and 3 Beacons fitted.

STA2 with Sounder and 2 Beacons fitted.

2

Order Code	ST-L101X Xenon Beacon				ST-L101H LED Beacon			Alarm Sounder		
	Nominal Voltage	Voltage Range	Nominal Current	Max Current	Voltage Range	Nominal Current†	Max Current	Voltage Range	Nominal Current	Max Current
STA*DC024AA0A1[x]	12 vdc	11.5-14 vdc	500mA	531mA @14 vdc	10-14 vdc	168mA	168mA @14 vdc	10-30 vdc	12mA	12mA @30 vdc
	24 vdc	20-28 vdc	250mA	271mA @20 vdc	16-33 vdc	179mA	183mA @33 vdc	10-30 vdc	12mA	12mA @30 vdc
STA*AC115AA0A1[x]	115 vac	+/-10%	70mA	101mA @126.5 vac	48-260 vac	86mA	166mA @48 vac	+/-10%	27mA	27mA @115 vac
STA*AC230AA0A1[x]	230 vac	+/-10%	35mA	58mA @253 vac	48-260 vac	53mA	166mA @48 vac	+/-10%	39mA	39mA @230 vac

†Worst case settings (Steady On Mode), refer to ST-L101H unit Instructions for full data
 *Denotes Number of Beacons (2, 3, or 4)
 [x] Denotes Housing Colour: R = Red; G = Grey; W = White

For Voltage Ranges of complete units, take the highest Minimum value and lowest Maximum value in the ranges of the component units
 For Current and Max Current Ratings of complete units, add the ratings from the component units:

Nominal Voltage	Alarm Sounder	ST-L101HDC024A1[y]	ST-L101HDC024A1[y]	ST-L101XDC024A1[y]	ST-L101XDC024A1[y]	24V DC
Voltage Range	10 - 30 V DC	16 - 33 V DC	16 - 33 V DC	20 - 28 V DC	20 - 28 V DC	20 - 28 V DC
Current	12mA	179mA	179mA	250mA	250mA	873mA
Max Current	12mA	183mA	183mA	271mA	271mA	923mA

4 Alarm Sounder Cabling

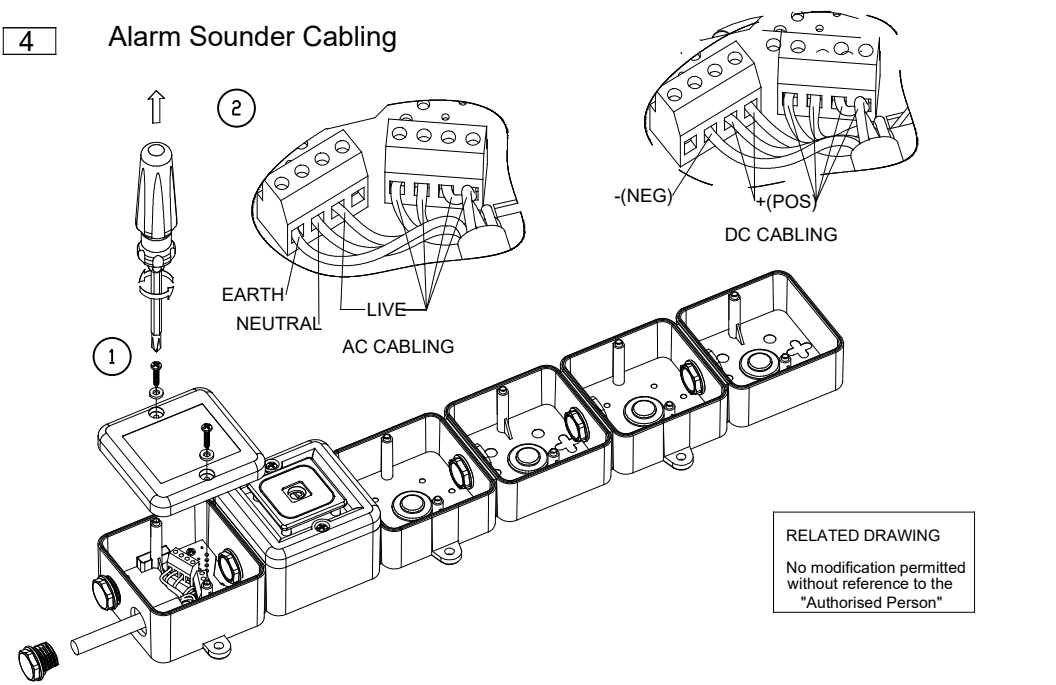

RELATED DRAWING
 No modification permitted without reference to the "Authorised Person"

5

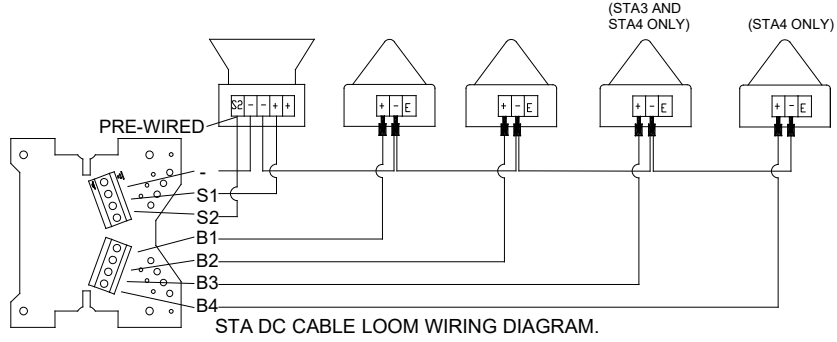
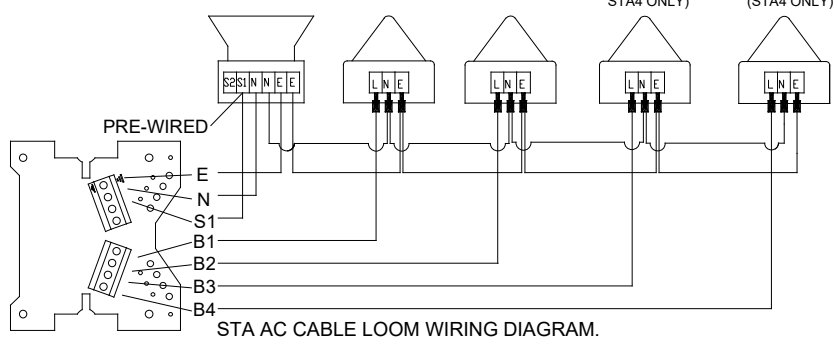
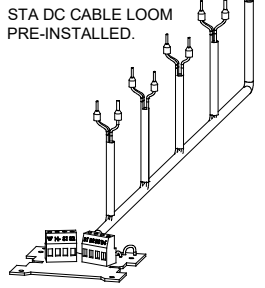
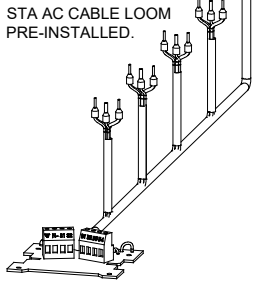

6

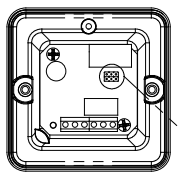

Alarm Sounder AC

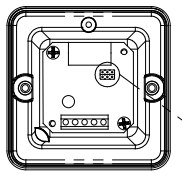

Alarm Sounder DC

Stage1 tone	Frequency Description	SONF1 AC dB@ 1m
Tone 1	800/1000Hz @ 0.25 sec Alternating	99dB(A) @ 1m
Tone 2	500/1200Hz @ 0.3Hz 0.5 sec Slow Whoop	100dB(A) @ 1m
Tone 3	1200/500Hz @ 1Hz - DIN / PFEER P.T.A.P.	99dB(A) @ 1m
Tone 4	544Hz (100mS)/440Hz (400mS) - NF S 32-001	97dB(A) @ 1m
Tone 5	1000Hz Continuous - PFEER Toxic Gas	100dB(A) @ 1m
Tone 6	Bell	95dB(A) @ 1m
Tone 7	800/1000Hz @ 7Hz Sweeping	99dB(A) @ 1m
Tone 8	2400/2900Hz @ 50Hz Sweeping	100dB(A) @ 1m
Tone 9	420Hz @ 0.625 sec Australian Alert	97dB(A) @ 1m
Tone 10	500-1200Hz 3.75sec / 0.25 sec Australian Evac.	100dB(A) @ 1m

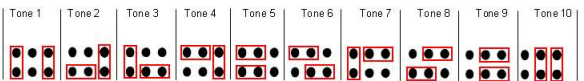

NOTE: Tone Selection: to select a tone place the pin link in the position shown above Fig.1

Stage1 tone	Frequency Description	SONF1 dB@ 1m	Stage2 (S2)
Tone 1	800/1000Hz @ 0.25 sec Alternating	99dB(A) @ 1m	Tone 8
Tone 2	500/1200Hz @ 0.3Hz 0.5 sec Slow Whoop	100dB(A) @ 1m	Tone 1
Tone 3	1200/500Hz @ 1Hz - DIN / PFEER P.T.A.P.	99dB(A) @ 1m	Tone 8
Tone 4	544Hz (100mS)/440Hz (400mS) - NF S 32-001	97dB(A) @ 1m	Tone 9
Tone 5	Bell	95dB(A) @ 1m	Tone 1
Tone 6	800/1000Hz @ 7Hz Sweeping	99dB(A) @ 1m	Tone 8
Tone 7	500-1200Hz 3.75sec / 0.25 sec Australian Evac.	100dB(A) @ 1m	Tone 10
Tone 8	1000Hz Continuous - PFEER Toxic Gas	100dB(A) @ 1m	-
Tone 9	544Hz Continuous	97dB(A) @ 1m	-
Tone 10	420Hz @ 0.625 sec Australian Alert	97dB(A) @ 1m	-

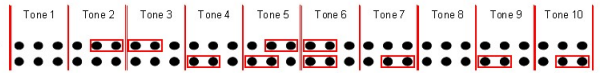

NOTE: Tone Selection: to select a tone place the pin link in the position shown above Fig.1. To set tones 8,9 or 10 as a first stage connect terminal 'S2' to '-' terminal.

7

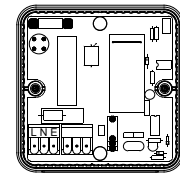

ST-L101X Xenon Beacon

Refer to D171-10-800-IS for full details of ST-L101X Xenon Beacon

ST-L101H LED Beacon

Refer to D171-10-900-IS for full details of ST-L101H LED Beacon

12V DC & 24V DC Terminals

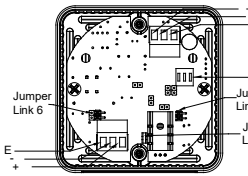

DC TERMINAL	CABLE COLOUR
EARTH	WHITE
LIVE	BLACK
+VE	BLACK

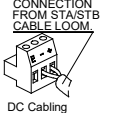

DC Cabling

AC Units: 115V AC & 230V AC Terminals

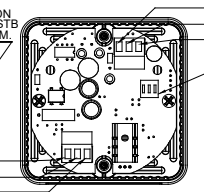

AC TERMINAL	CABLE COLOUR
EARTH	GREEN
LIVE	BLACK
NEUTRAL	WHITE

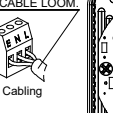

AC Cabling

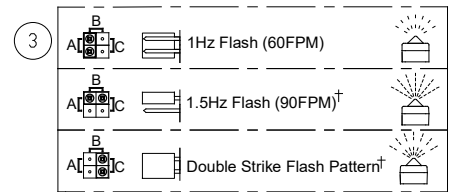

Flashing 1.5Hz and Double Strike modes are not available when used with an AC supply.

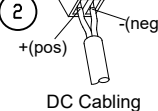
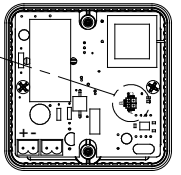

DC Cabling

Reference for Voltage Link Settings (DC only)

Jumper Setting	Jumper Link 4	Jumper Link 5	Jumper Link 6
24VDC Mode (Default)	Open	Closed	Open
12VDC Mode (Customer set)	Closed	Open	Closed

Flash Pattern Settings (AC & DC Units)

Switch Setting	Flash Mode
(0 0 0)	Steady On
(1 0 0)	Blinking
(0 1 0)	Flashing 1Hz
(1 1 0)	Flashing 1.5Hz
(0 0 1)	Flashing Double Strike
(1 0 1)	Flashing Triple Strike
(0 1 1)	Flashing 2Hz
(1 1 1)	Flashing - Temporal

8

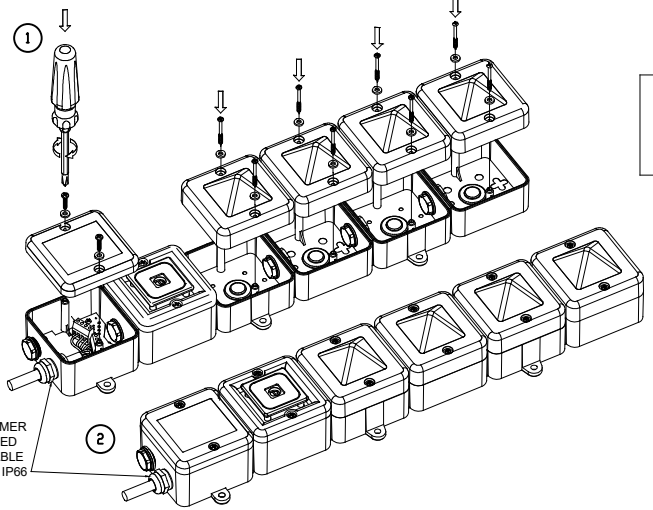

RELATED DRAWING

No modification permitted without reference to the "Authorised Person"

CUSTOMER SUPPLIED M20 CABLE GLAND IP66