

Visual Signals - Industrial LIGHT EMITTING DIODE BEACONS



E-Flare Battery Operated > LED Portable Beacon

Product overview

Suitable for a wide range of applications the E-Flare beacon has been designed with versatility in mind. The unit provides a highly visible warning zone, day or night.

These beacons are single colour only and incorporate a failsafe activation switch to prevent

accidental turn on or off and come with a range of accessories.

The EF350 beacon is an economy option, powered by four 'AA' Cell Alkaline batteries (not supplied) that will provide at least 30 hours of peak brightness operation and comes with a lanyard (as standard) for hanging/wearing the unit.

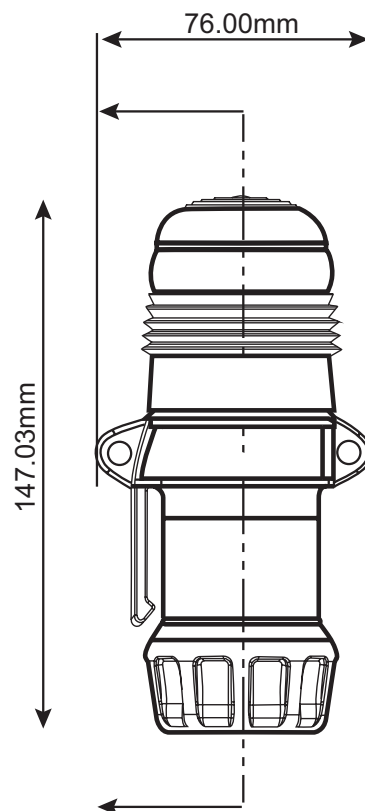

LED Portable Beacon > Ordering Information

Code No:	Voltage:	Light Source:
LED-P-EF350-01 (Amber)	3v Dc ---	4 LEDs
LED-P-EF350-01B (Amber Pk 12)	3v Dc ---	4 LEDs
LED-P-EF350-02 (Red)	3v Dc ---	4 LEDs
LED-P-EF350-02B (Red Pk 12)	3v Dc ---	4 LEDs

Accessories

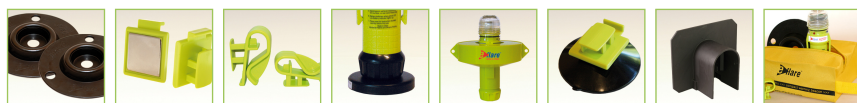

50170 Standard Base 50172 Magnetic Clip 50173 Cone Clip 50174 Magnetic Base 50175 Flotation Collar 50176 Suction Cup 50177 Daylight Hood 50178 Carry Bag

Features

- Continuously rated
- LED long life
- Shock resistant
- Ultra quick installation
- Versatile accessory options
- 360° light output around the vertical axis
- Special bulk pack pricing
- Dustproof and Weatherproof

Material

UV Stable Polycarbonate Lens
UV Stable ABS Body

Kg 0.16

°C -20+50

IP 66

FPM 160

INDUSTRIAL

AUTOMOTIVE

MARINE

APPROVALS and
CONFORMITIES

