

MV121 Appello X User recordable alarm horn

The MV121 Appello X is the next generation of user recordable alarm sounder capable of storing up to 2 minutes of content. The MV121 records, stores and plays back with unsurpassed clarity, user defined voice messages, music or sounds stored directly to non-volatile memory. Low current consumption and CD quality reproduction in a robust fire retardant Type 4/4X/3R/13, IP66/67 housing ensure the MV121 Appello X is suitable for all general signalling applications including fire, security and process control.

Tone table:

Stage 1	Frequency Description	Stg 2	Stg 3	Stg 4
Tone 1	340 Hz Continuous	Tone 2	Tone 5	Tone 29
Tone 2	800/1000Hz @ 0.25 sec Alternating - BS5839 Alarm tone	Tone 17	Tone 5	Tone 29
Tone 3	500/1200Hz @ 0.3Hz 0.5 sec Slow Whoop - NEN 2575:2000	Tone 2	Tone 5	Tone 29
Tone 4	800/1000Hz @ 1Hz Sweeping	Tone 6	Tone 5	Tone 29
Tone 5	2400Hz Continuous	Tone 3	Tone 20	Tone 29
Tone 6	2400/2900Hz @ 7Hz Sweeping	Tone 7	Tone 5	Tone 29
Tone 7	2400/2900Hz @ 1Hz Sweeping	Tone 10	Tone 5	Tone 29
Tone 8	500/1200/500Hz @ 0.3Hz Sweeping	Tone 2	Tone 5	Tone 29
Tone 9	1200/500Hz @ 1Hz - DIN / PFEER P.T.A.P.	Tone 15	Tone 2	Tone 29
Tone 10	2400/2900Hz @ 2Hz Alternating	Tone 7	Tone 5	Tone 29
Tone 11	1000Hz @ 1Hz Intermittent	Tone 2	Tone 5	Tone 29
Tone 12	800/1000Hz @ 0.875Hz Alternating	Tone 4	Tone 5	Tone 29
Tone 13	2400Hz @ 1Hz Intermittent	Tone 15	Tone 5	Tone 29
Tone 14	800Hz 0.25sec on, 1 sec off Intermittent	Tone 4	Tone 5	Tone 29
Tone 15	800Hz Continuous	Tone 2	Tone 5	Tone 29
Tone 16	660Hz 150mS on, 150mS off Intermittent	Tone 18	Tone 5	Tone 29
Tone 17	544Hz (100mS)/440Hz (400mS) - AFNOR NF S 32-001	Tone 2	Tone 27	Tone 29
Tone 18	660Hz 1.8sec on, 1.8sec off Intermittent	Tone 2	Tone 5	Tone 29
Tone 19	1.4KHz-1.6KHz 1s, 1.6KHz-1.4KHz 0.5s - AFNOR NFC48-265	Tone 2	Tone 5	Tone 29
Tone 20	660Hz Continuous	Tone 2	Tone 5	Tone 29
Tone 21	554Hz/440Hz @ 1Hz Alternating	Tone 2	Tone 5	Tone 29
Tone 22	544Hz @ 0.875 sec. Intermittent	Tone 2	Tone 5	Tone 29
Tone 23	800Hz @ 2Hz Intermittent	Tone 6	Tone 5	Tone 29
Tone 24	800/1000Hz @ 50Hz Sweeping	Tone 29	Tone 5	Tone 29
Tone 25	2400/2900Hz @ 50Hz Sweeping	Tone 29	Tone 5	Tone 29
Tone 26	Bell	Tone 2	Tone 15	Tone 29
Tone 27	554Hz Continuous	Tone 26	Tone 5	Tone 29
Tone 28	440Hz Continuous	Tone 2	Tone 5	Tone 29
Tone 29	800/1000Hz @ 7Hz Sweeping	Tone 7	Tone 5	Tone 29
Tone 30	300Hz Continuous	Tone 2	Tone 5	Tone 29
Tone 31	660/1200Hz @ 1Hz Sweeping	Tone 26	Tone 5	Tone 29
Tone 32	Two tone chime.	Tone 26	Tone 15	Tone 29
Tone 33	745Hz @ 1Hz Intermittent	Tone 2	Tone 5	Tone 29
Tone 34	1000 & 2000Hz @ 0.5 sec Alternating - Singapore	Tone 38	Tone 45	Tone 29
Tone 35	420Hz @ 0.625 sec Australian Alert - AS2220	Tone 36	Tone 5	Tone 29
Tone 36	500-1200Hz 3.75sec /0.25sec. Australian Evac. - AS2220	Tone 35	Tone 5	Tone 29
Tone 37	1000Hz Continuous - PFEER Toxic Gas	Tone 9	Tone 45	Tone 29
Tone 38	2000Hz Continuous	Tone 34	Tone 45	Tone 29
Tone 39	800Hz 0.25sec on, 1 sec off Intermittent	Tone 23	Tone 17	Tone 29
Tone 40	544Hz (100mS)/440Hz (400mS) - AFNOR NF S 32-001	Tone 31	Tone 27	Tone 29
Tone 41	Motor Siren - slow rise to 1200 Hz	Tone 2	Tone 5	Tone 29
Tone 42	Motor Siren - slow rise to 800 Hz	Tone 2	Tone 5	Tone 29
Tone 43	1200 Hz Continuous	Tone 2	Tone 5	Tone 29
Tone 44	Motor Siren - slow rise to 2400 Hz	Tone 2	Tone 5	Tone 29
Tone 45	1KHz 1s on, 1s off Intermittent - PFEER Gen. Alarm	Tone 38	Tone 34	Tone 29

Country specific or custom tone configurations and alarm frequencies are available upon request.

Part codes:

Version:	Part code:
14-30V dc	MV121DC024G-UL
90-260V ac	MV121AC230G-UL

Current consumption:

Version:	Voltage:	Current :
24V dc	14-30V dc	1.51A*
230V ac	90-260V ac 50/60Hz	517mA*

* current at nominal voltage on Tone 1

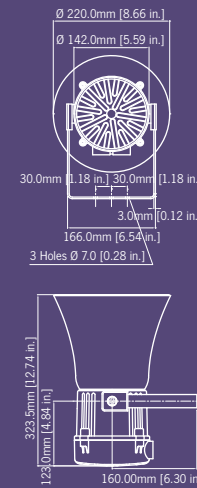
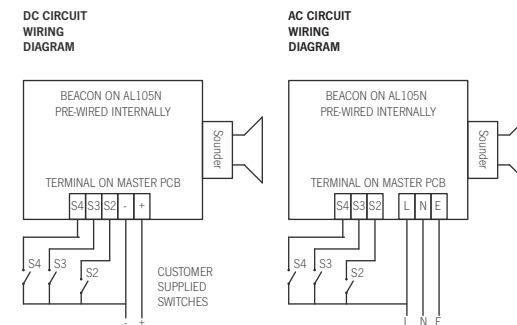

Specification:

Voice content output:	111dB(A) @ 1 metre
Music content output:	112dB(A) @ 1 metre
Alarm tone output:	126dB(A) @ 1 metre
No. of alarm tones:	45 (UK00A/PFEER compliant)
No. of messages:	4 (30 seconds each)
Volume controls:	Independent controls for user recorded content and built-in alarm tones.
Effective range:	300m @ 1KHz
Voltagess DC:	24vdc (14-30vdc)
Voltagess AC:	90-260vac 50/60Hz
Ingress protection:	Type 4 / 4X / 3R / 13, IP66/67
Rating:	Continuous
Housing material:	UL94V0 & 5VA FR ABS
Housing colour:	RAL7038 Grey
Fixings:	Stainless Steel
Cable entries:	2 x M20 threaded gland entries.
Terminals:	0.5 to 2.5mm ²
Operating temp:	-25° to +55°C
Storage temp:	-40° to +70°C
Relative humidity:	90% at 20°C
Weight :	DC: 2.10kg AC: 2.70kg

Features:

The MV121 Appello user recordable unit enables the recording of any type of content such as voice or music that can be played back at CD quality output at SPL's of up to 112dB(A) at 1 metre. This content can be reproduced repeatedly, alternating with or without one of the built-in 45 alarm tones. The alarm tone notification has an output of up to 126dB(A) at 1 metre.

For multiple unit installations the recording process is only required once to create a master unit which can then be used to program all other MV121 units on the system, guaranteeing synchronisation during playback, using the supplied 'Synch' cable.

- Direct content storage on non-volatile memory.
- CD quality reproduction.
- Message length: 4 x 30 seconds
- Easy message creation with built in microphone or line-in audio input.
- Volume controls for user content and alarm tones.
- Available with custom tone configurations and frequencies.
- Factory programming of user supplied content also available.
- UL approved for general signalling use.