



# SX

The SX range comprises 14 sizes of enclosure manufactured in either stainless steel or mild steel. 11 sizes are available in depths of 140 or 200mm and 8 sizes are available in depths of 140, 200 or 300mm. The majority of the range can be fitted with removable gland plates on any or all of the four sides. The SX Range is available with a number of paint options (most RAL colours are available) and anti-corrosion finishes. Further advice on surface finishes can be sought from the ABTECH sales office.



The stainless steel range (SSX) is manufactured in 316 grade stainless steel to give the maximum environmental protection.

The main body is manufactured from 2mm thick sheet and the mounting straps and gland plates from 3mm thick plate. Cable entries can be drilled in the enclosure door or sides or through the gland plates, if fitted. Entries may also be drilled through the rear face of the enclosure (EEx'e' versions also.)

Another important feature of the SX range is the hinged, lift-off door, which is held to the enclosure by at least 4 captive stainless steel screws, which also maintain the correct compression on the gasket. The hinges are solid block, machined oversize to enable the screws to control the closing of the door, not the hinge, its only function being to support the door when opened. The hinges allow easy removal of the door with only minimal opening required before removal (less than 10°).

Earthing is accomplished by means of an internal /external earth stud fitted as standard which can be connected to the terminal mounting rail or component mounting plate.

Optionally, earth studs can be fitted to the door and gland plates. Rail mounted earth terminals or proprietary earth bars can be fitted inside the enclosure and ABTECH Sales staff will be happy to advise on this. The SX range is suitable for a wide range of ambient conditions. Hazardous Area certified enclosures are suitable for -50°C to + 175°C. Non-Ex versions are suitable from -60°C to + 200°C.

The SX range of enclosures are suitable for use in hazardous areas and can be supplied with a number of certificates. ATEX EEx'e' to BS EN 50019 (Zone 1 & 2) EEx'nA' to BS EN50021 (Zone 2), NEMA 4X (CSA, UL & FM class 1, div 2), IEC Ex and GOST. The range can be supplied fitted with any component approved terminal to apparatus level or can be supplied empty as component approved for the clients own certification requirements.

The SX range was specifically designed to meet the rigours of the North Sea environment and is capable of achieving IP66 and IP67. It has also undergone and passed the Shell/ERA deluge test which was devised to adequately test enclosures and electrical equipment which is routinely subjected to ships deck conditions or fire deluge systems.

IP68 enclosures are also available for depths up to 120 ft to special order. Further information on submersible enclosures is available in Section 8 of this catalogue.



The SX range has many features which lend itself to a wide variety applications, not least of which is the ability to be constructed to almost any dimension due to its fabricated nature. This can also be applied to EEx'e' enclosures where the certification allows oversized enclosures to be manufactured whilst retaining the next smallest sized enclosure's power rating.

The SX range is also suitable for fire resistance applications and when fitted with ceramic terminals meets the requirements of IEC 331 (750°C (1382°F) for 3 hours) and also BS6387/1983 (950°C (1742°F) for 3 hours). Further details are available in Section 6 of this catalogue.



Other applications include junction boxes, both industrial and hazardous area, OEM applications, fire protection systems, tunnel wiring, IP68 applications, etc.

Abtech also offers bespoke solutions for Ex nR restricted breathing applications.

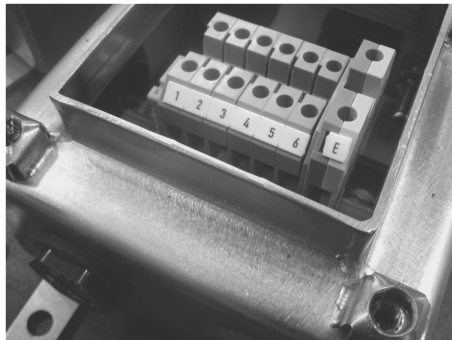

### SX Range Features

- Wide Operating Temperature (-50°C to +175°C) (-58°F to +347°F)
- Ingress Protection up to IP68
- Fire Resistant to IEC331
- Impact Resistant > 10 Nm
- Corrosion Resistant
- Gland plates can be fitted to any or all four sides (size SX66 and above)
- Certification for use in Zone 1 and 2
- UL, CSA, IEC Ex, ATEX, FM, InMetro and TR CU Approvals
- Ideal for Petrochemical and Marine applications

### Certification and Coding

	Zone 0	Zone 20	Zone 1	Zone 21	Zone 2	Zone 22
Ex e			•	•	•	•
Ex al	•	•	•	•	•	•
Ex ab			•	•	•	•
Ex op is	•	•	•	•	•	•
Ex nA					•	•
Ex nR					•	•

Available with Apparatus or Component certification

## Accessories and Options

The following table is a list of the available accessories suitable for particular standard sizes of SX enclosures. Care should be taken when ordering accessories for use with enclosures intended for hazardous areas to ensure that compliance with certification is retained.

Part Number (see note 1)	Width (mm) (see note 2)	Height (mm) (see note 2)	Depth (mm) (see note 2)	140mm Depth	200mm Depth	300mm Depth	Gland Plates (on any or all four sides)	EP – Electro-polished external surfaces (SX only)	LB - Label Bracket Welded to Door	ES - Earth Stud fitted to Door and Gland Plates	EB - Internal Earthing Bar	BD - Breather Drain (see note 3)	IP - Tamper Proof Lid Fixing Screws	MP - Component Mounting Plate (Steel/Stainless Steel)	RF - RFI Protection (see note 4)
SX45	114	114	51					●	●			●	●	●	●
SX64	102	152	63					●	●			●	●	●	●
SX66	152	152	102				●	●	●	●	●	●	●	●	●
SX0	152	229		●	●		●	●	●	●	●	●	●	●	●
SX0.5	184	274		●	●		●	●	●	●	●	●	●	●	●
SX1	234	324		●	●		●	●	●	●	●	●	●	●	●
SX1.5	306	306		●	●	●	●	●	●	●	●	●	●	●	●
SX2	372	324		●	●	●	●	●	●	●	●	●	●	●	●
SX3	372	448		●	●	●	●	●	●	●	●	●	●	●	●
SX4	372	510		●	●	●	●	●	●	●	●	●	●	●	●
SX5	510	510		●	●	●	●	●	●	●	●	●	●	●	●
SX6	510	780		●	●	●	●	●	●	●	●	●	●	●	●
SX7	650	950		●	●	●	●	●	●	●	●	●	●	●	●
SX8	800	1250		●	●	●	●	●	●	●	●	●	●	●	●

Ordering Example;

**SX1.5 300 4GP LB EB**

(Stainless Steel SX1.5 300mm deep, 4 gland plates, label bracket on door and internal earthing bar)

1. The range is available either in stainless steel 316 (SX variants) or mild steel (MSX variants).
2. Manufacturing tolerances are +/- 3mm on overall dimensions and +/-0.5mm on fixing hole centres.
3. Breather drain available in IP66 stainless steel or plastic.
4. Radio Frequency Interference (RFI) gasket may reduce IP rating.



Full width, full height Gland Plates  
(can be fitted to any or all sides)

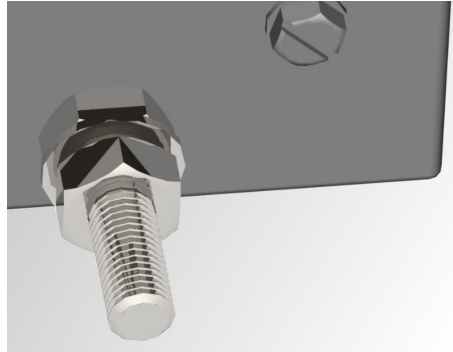

Earth Stud fitted to door and gland plates

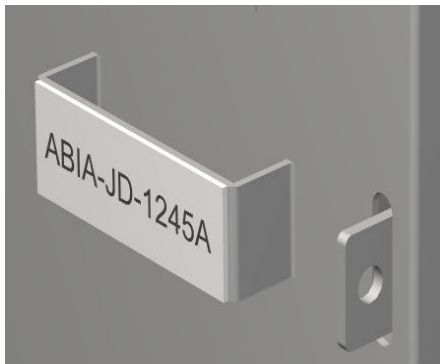

Label Bracket  
(welded to door)



Electro-polished  
(external surfaces on SX range only)

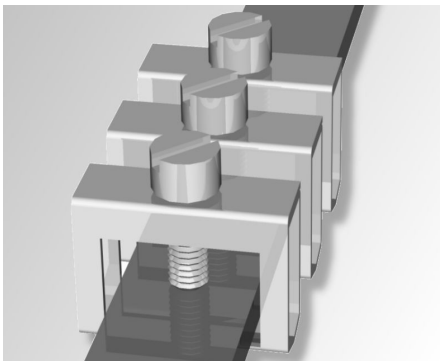

Internal Earthing bar  
(can be fitted with clamps)

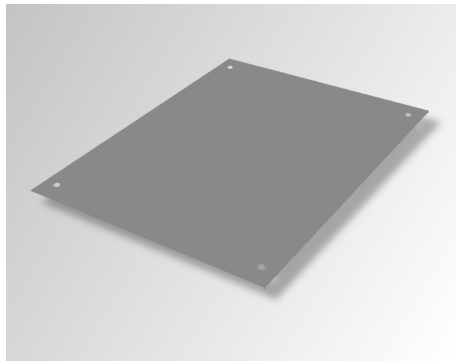

Component Mounting Plate  
(steel or stainless steel 316)

# SX45 / MSX45

Stainless Steel and Mild Steel Enclosures

IP66/7

Stainless Steel and Mild Steel Enclosures

### Application

Hazardous and Industrial areas

### Protection Degree

IP66 or 67

### Certification

ATEX & IECEx (Zone 0, 1 & 2; Zone 20, 21 & 22)  
 CSA Ex e (Class 1 Zone 1 & Zone 2)  
 FM AEx e (Class 1 Zone 1 & Zone 2)  
 TR CU Ex e (Zone 1 & Zone 2)  
 NEMA 4X (CSA, UL & FM)  
 Class 1 Division 2

### Material

Stainless steel 316 (1.4404) or Mild steel

### Temperature Rating

Hazardous Area: -50°C to +175°C  
 Non Hazardous: -60°C to +200°C

### Power Rating

8.00W



### Terminal Populations (Maximum Number of Rails = 1)

Calculations do not include the use of end stops, end plates and separators. Check that the enclosure can accommodate the cable bending radius and that the earth stud and entry location will permit the required number of terminals to be fitted

Weidmüller		Phoenix		Wago	
SAK 2.5	7	UK 2.5 N	9	280-992	8
SAK 4	7	UK 3 N	9	280-999	0
SAK 6	0	UK 5 N	7	281-691	7
SAK 10	0	UK 10 N	4	281-992	7
SAK 16	0	UK 16 N	3	281-993	0
SAK 35	0	UK 35 N	0	282-691	0
SAK 70	0			284-691	0
WDU 2.5	0			283-691	0
WDU 4	0			285-691	0
WDU 6	0			280-998	8
WDU 10	0			281-998	0
WDU 16	0			264-120	7
				264-220	4
				264-132(2)	1
				264-134(4)	1
				262-132(2)	1
				264-134(4)	1

### Drilling Envelope Dimensions (mm)

	Side A - C	Side B - D
Width	114	114
Height	51	51

### Gland Entry Matrix \*

Size	Side A - C	Side B - D
M16	4	4
M20	2	2
M25	2	2
M32	0	0
M40	0	0

\* Using standard gland clearances

### Specifications

Part Number	Material	Width (mm)	Length (mm)	Depth (mm)	Weight (g)
SX45	Stainless Steel	114	114	51	1200
MSX45	Mild Steel	114	114	51	1200

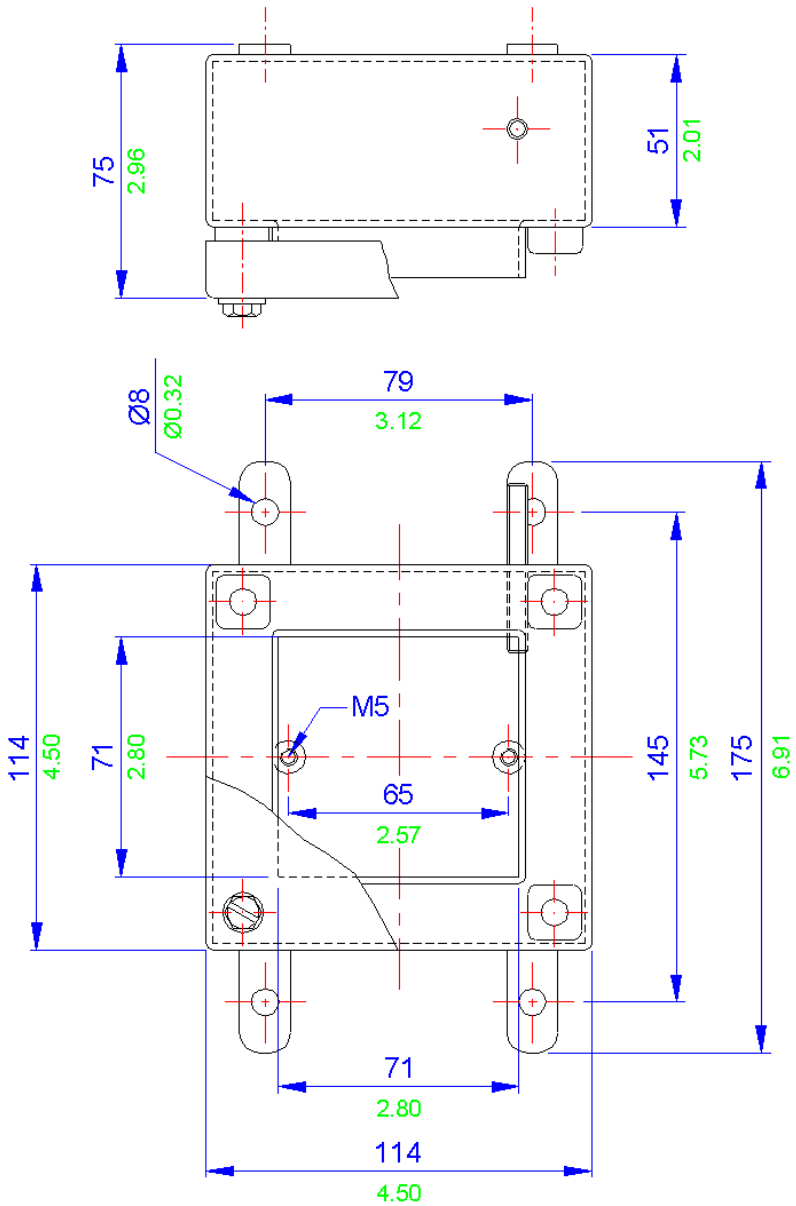

All blue dimensions in mm, all green dimensions in decimal inches (drawing not to scale)



**Application**

Hazardous and Industrial areas

**Protection Degree**

IP66 or 67

**Certification**

ATEX & IECEx (Zone 0, 1 & 2; Zone 20, 21 & 22)  
 CSA Ex e (Class 1 Zone 1 & Zone 2)  
 FM AEx e (Class 1 Zone 1 & Zone 2)  
 TR CU Ex e (Zone 1 & Zone 2)  
 NEMA 4X (CSA, UL & FM)  
 Class 1 Division 2

**Material**

Stainless steel 316 (1.4404) or Mild steel

**Temperature Rating**

Hazardous Area: -50°C to +175°C  
 Non Hazardous: -60°C to +200°C

**Power Rating**

10.258W

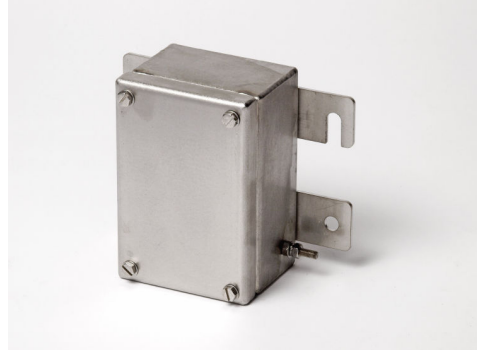

**Terminal Populations (Maximum Number of Rails = 1)**

Calculations do not include the use of end stops, end plates and separators. Check that the enclosure can accommodate the cable bending radius and that the earth stud and entry location will permit the required number of terminals to be fitted

Weidmuller	
SAK 2.5	15
SAK 4	15
SAK 6	11
SAK 10	9
SAK 16	0
SAK 35	0
SAK 70	0
WDU 2.5	0
WDU 4	0
WDU 6	0
WDU 10	0
WDU 16	0

Phoenix	
UK 2.5 N	17
UK 3 N	17
UK 5 N	15
UK 10 N	9
UK 16 N	7
UK 35 N	0

Wago	
280-992	18
280-999	0
281-691	15
281-992	15
281-993	0
282-691	0
284-691	0
283-691	0
285-691	0
280-998	18
281-998	15
264-120	15
264-220	9
264-132(2)	3
264-134(4)	2
262-132(2)	3
264-134(4)	2

**Drilling Envelope Dimensions (mm)**

	Side A - C	Side B - D
Width	102	152
Height	63	63

**Gland Entry Matrix \***

Size	Side A - C	Side B - D
M16	6	8
M20	3	4
M25	2	3
M32	1	2
M40	0	0

\* Using standard gland clearances

**Specifications**

Part Number	Material	Width (mm)	Length (mm)	Depth (mm)	Weight (g)
SX64	Stainless Steel	102	152	63	1500
MSX64	Mild Steel	102	152	63	1500

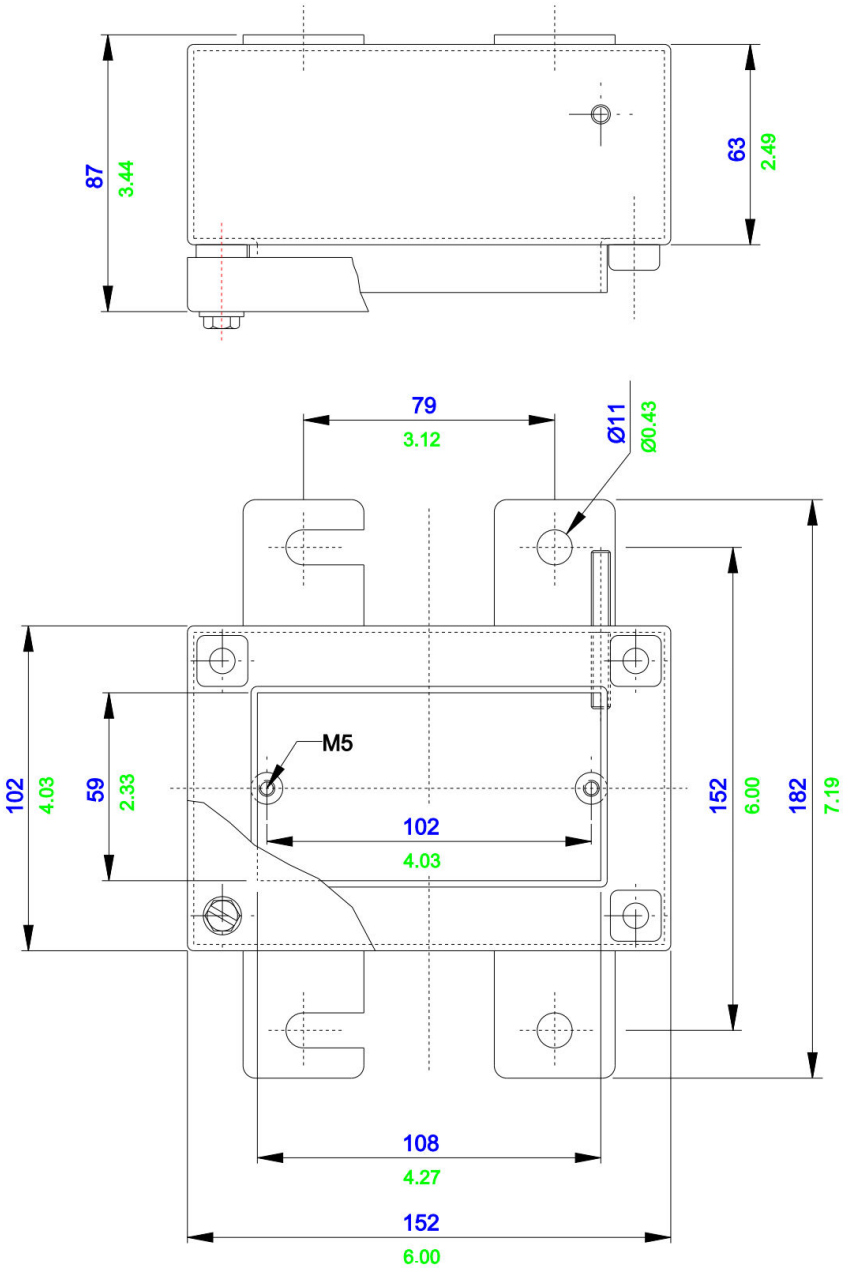

All blue dimensions in mm, all green dimensions in decimal inches (drawing not to scale)

### Application

Hazardous and Industrial areas

### Protection Degree

IP66 or 67

### Certification

ATEX & IECEx (Zone 0, 1 & 2; Zone 20, 21 & 22)  
 CSA Ex e (Class 1 Zone 1 & Zone 2)  
 FM AEx e (Class 1 Zone 1 & Zone 2)  
 TR CU Ex e (Zone 1 & Zone 2)  
 NEMA 4X (CSA, UL & FM)  
 Class 1 Division 2

### Material

Stainless steel 316 (1.4404) or Mild steel

### Temperature Rating

Hazardous Area: -50°C to +175°C  
 Non Hazardous: -60°C to +200°C

### Power Rating

14.287W



### Terminal Populations (Maximum Number of Rails = 1)

Calculations do not include the use of end stops, end plates and separators. Check that the enclosure can accommodate the cable bending radius and that the earth stud and entry location will permit the required number of terminals to be fitted

Weidmuller	
SAK 2.5	15
SAK 4	15
SAK 6	11
SAK 10	9
SAK 16	7
SAK 35	6
SAK 70	0
WDU 2.5	17
WDU 4	15
WDU 6	11
WDU 10	9
WDU 16	7

Phoenix	
UK 2.5 N	17
UK 3 N	17
UK 5 N	14
UK 10 N	9
UK 16 N	7
UK 35 N	6

Wago	
280-992	18
280-999	18
281-691	15
281-992	15
281-993	15
282-691	11
284-691	10
283-691	7
285-691	0
280-998	18
281-998	15
264-120	16
264-220	10
264-132(2)	3
264-134(4)	2
262-132(2)	3
264-134(4)	2

### Drilling Envelope Dimensions (mm)

	Side A - C	Side B - D
Width	152	152
Height	102	102

### Gland Entry Matrix \*

Size	Side A - C	Side B - D
M16	4	4
M20	2	2
M25	2	2
M32	0	0
M40	0	0

\* Using standard gland clearances

### Specifications

Part Number	Material	Width (mm)	Length (mm)	Depth (mm)	Weight (g)
SX66	Stainless Steel	152	152	102	2200
MSX66	Mild Steel	152	152	102	2200

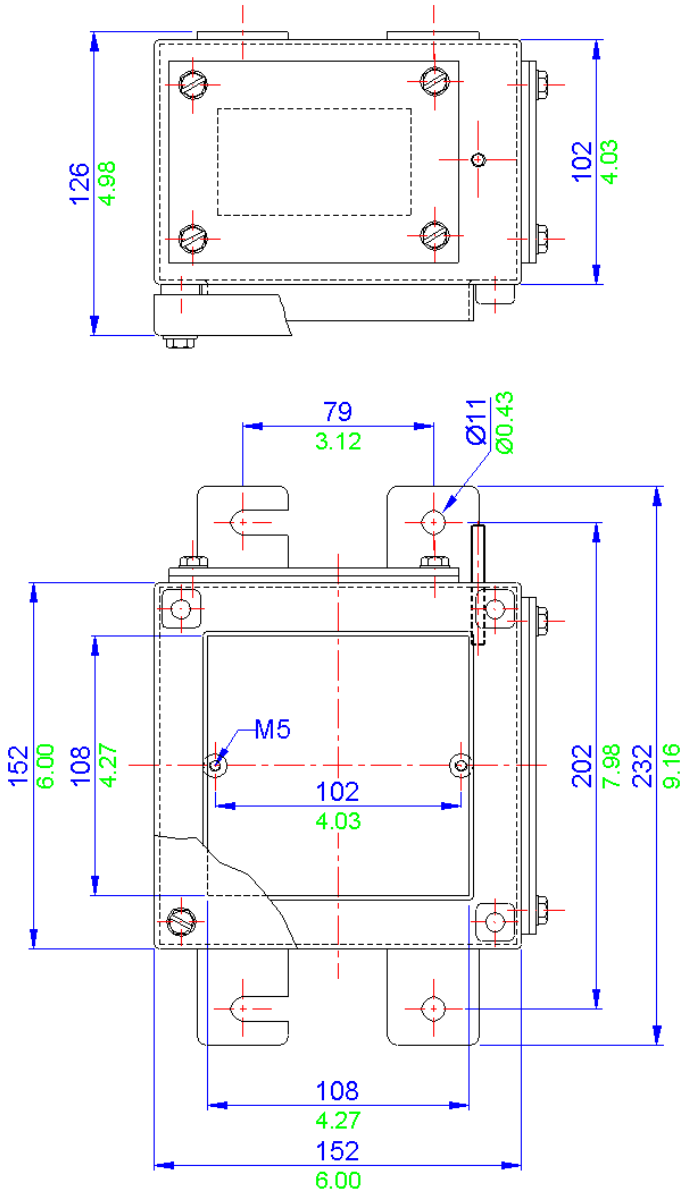

All blue dimensions in mm, all green dimensions in decimal inches (drawing not to scale)

**Application**

Hazardous and Industrial areas

**Protection Degree**

IP66 or 67

**Certification**

ATEX & IECEx (Zone 0, 1 & 2; Zone 20, 21 & 22)  
 CSA Ex e (Class 1 Zone 1 & Zone 2)  
 FM AEx e (Class 1 Zone 1 & Zone 2)  
 TR CU Ex e (Zone 1 & Zone 2)  
 NEMA 4X (CSA, UL & FM)  
 Class 1 Division 2

**Material**

Stainless steel 316 (1.4404) or Mild steel

**Temperature Rating**

Hazardous Area: -50°C to +175°C  
 Non Hazardous: -60°C to +200°C

**Power Rating**

19.874W

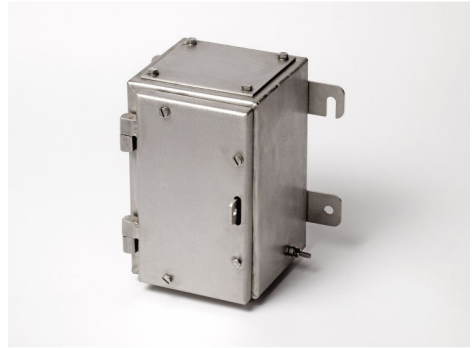

**Terminal Populations (Maximum Number of Rails = 1)**

Calculations do not include the use of end stops, end plates and separators. Check that the enclosure can accommodate the cable bending radius and that the earth stud and entry location will permit the required number of terminals to be fitted

Weidmuller	
SAK 2.5	21
SAK 4	19
SAK 6	16
SAK 10	12
SAK 16	10
SAK 35	7
SAK 70	5
WDU 2.5	25
WDU 4	21
WDU 6	16
WDU 10	12
WDU 16	10

Phoenix	
UK 2.5 N	25
UK 3 N	25
UK 5 N	21
UK 10 N	12
UK 16 N	10
UK 35 N	8

Wago	
280-992	24
280-999	24
281-691	20
281-992	20
281-993	20
282-691	15
284-691	12
283-691	0
285-691	0
280-998	24
281-998	20
264-120	21
264-220	12
264-132(2)	4
264-134(4)	3
262-132(2)	4
264-134(4)	3

**Drilling Envelope Dimensions (mm)**

	Side A - C		Side B - D	
	140	200	140	200
Width	87	87	144	144
Height	75	135	75	135

\* With glandplate fitted

**Gland Entry Matrix \***

Size	Side A - C		Side B - D	
	140	200	140	200
M16	4	9	8	16
M20	2	6	6	9
M25	1	4	3	6
M32	1	2	2	4
M40	1	1	2	2

\* Using standard gland clearances

**Specifications**

Part Number	Material	Width (mm)	Length (mm)	Depth (mm)	Weight (g)
SX0.140	Stainless Steel	152	229	140	3200
SX0.200	Stainless Steel	152	229	200	4000
MSX0.140	Mild Steel	152	229	140	3200
MSX0.200	Mild Steel	152	229	200	4000



**Application**

Hazardous and Industrial areas

**Protection Degree**

IP66 or 67

**Certification**

ATEX & IECEx (Zone 0, 1 & 2; Zone 20, 21 & 22)  
 CSA Ex e (Class 1 Zone 1 & Zone 2)  
 FM AEx e (Class 1 Zone 1 & Zone 2)  
 TR CU Ex e (Zone 1 & Zone 2)  
 NEMA 4X (CSA, UL & FM)  
 Class 1 Division 2

**Material**

Stainless steel 316 (1.4404) or Mild steel

**Temperature Rating**

Hazardous Area: -50°C to +175°C  
 Non Hazardous: -60°C to +200°C

**Power Rating**

19.874W



**Terminal Populations (Maximum Number of Rails = 2)**

Calculations do not include the use of end stops, end plates and separators. Check that the enclosure can accommodate the cable bending radius and that the earth stud and entry location will permit the required number of terminals to be fitted

Weidmuller		Phoenix		Wago	
SAK 2.5	56	UK 2.5 N	68	280-992	31
SAK 4	52	UK 3 N	68	280-999	31
SAK 6	42	UK 5 N	56	281-691	27
SAK 10	34	UK 10 N	34	281-992	27
SAK 16	14	UK 16 N	14	281-993	27
SAK 35	10	UK 35 N	11	282-691	21
SAK 70	7			284-691	16
WDU 2.5	67			283-691	28
WDU 4	56			285-691	0
WDU 6	42			280-998	31
WDU 10	34			281-998	27
WDU 16	14			264-120	56
				264-220	32
				264-132(2)	12
				264-134(4)	8
				262-132(2)	12
				264-134(4)	8

**Drilling Envelope Dimensions (mm)**

	Side A - C		Side B - D	
	140	200	140	200
Width	119	119	189	189
Height	75	135	75	135

\* With glandplate fitted

**Gland Entry Matrix \***

Size	Side A - C		Side B - D	
	140	200	140	200
M16	6	12	10	20
M20	4	9	8	12
M25	2	6	4	9
M32	2	4	3	6
M40	1	2	2	4

\* Using standard gland clearances

**Specifications**

Part Number	Material	Width (mm)	Length (mm)	Depth (mm)	Weight (g)
SX0.5.140	Stainless Steel	184	274	140	5000
SX0.5.200	Stainless Steel	184	274	200	6000
MSX0.5.140	Mild Steel	184	274	140	5000
MSX0.5.200	Mild Steel	184	274	200	6000

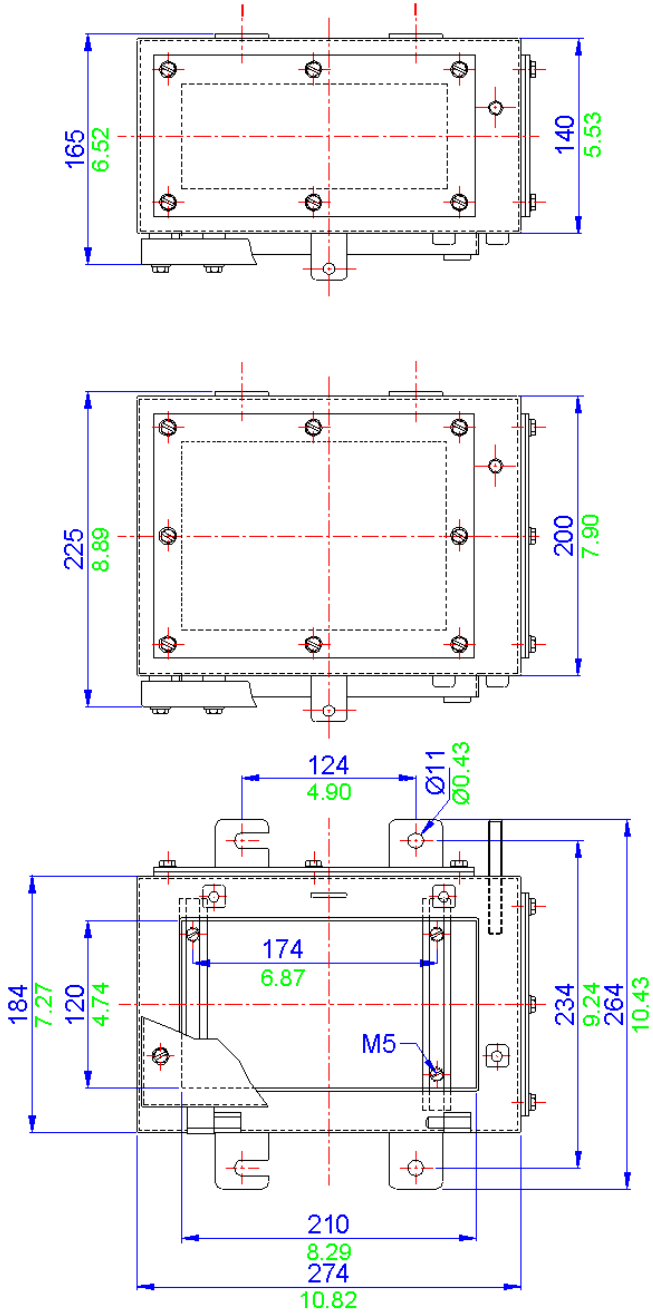

All blue dimensions in mm, all green dimensions in decimal inches (drawing not to scale)



**Application**

Hazardous and Industrial areas

**Protection Degree**

IP66 or 67

**Certification**

ATEX & IECEx (Zone 0, 1 & 2; Zone 20, 21 & 22)  
 CSA Ex e (Class 1 Zone 1 & Zone 2)  
 FM AEx e (Class 1 Zone 1 & Zone 2)  
 TR CU Ex e (Zone 1 & Zone 2)  
 NEMA 4X (CSA, UL & FM)  
 Class 1 Division 2

**Material**

Stainless steel 316 (1.4404) or Mild steel

**Temperature Rating**

Hazardous Area: -50°C to +175°C  
 Non Hazardous: -60°C to +200°C

**Power Rating**

29.206W



**Terminal Populations (Maximum Number of Rails = 2)**

Calculations do not include the use of end stops, end plates and separators. Check that the enclosure can accommodate the cable bending radius and that the earth stud and entry location will permit the required number of terminals to be fitted

Weidmuller	
SAK 2.5	72
SAK 4	66
SAK 6	54
SAK 10	44
SAK 16	18
SAK 35	14
SAK 70	10
WDU 2.5	86
WDU 4	72
WDU 6	54
WDU 10	44
WDU 16	18

Phoenix	
UK 2.5 N	86
UK 3 N	86
UK 5 N	72
UK 10 N	44
UK 16 N	18
UK 35 N	14

Wago	
280-992	41
280-999	41
281-691	34
281-992	34
281-993	34
282-691	27
284-691	21
283-691	18
285-691	12
280-998	41
281-998	34
264-120	72
264-220	42
264-132(2)	14
264-134(4)	10
262-132(2)	14
264-134(4)	10

**Drilling Envelope Dimensions (mm)**

	Side A - C		Side B - D	
	140	200	140	200
Width	169	169	239	239
Height	75	135	75	135

\* With glandplate fitted

**Gland Entry Matrix \***

Size	Side A - C		Side B - D	
	140	200	140	200
M16	10	20	14	28
M20	6	12	10	18
M25	3	9	5	12
M32	2	4	4	8
M40	2	2	3	6

\* Using standard gland clearances

**Specifications**

Part Number	Material	Width (mm)	Length (mm)	Depth (mm)	Weight (g)
SX1.140	Stainless Steel	234	324	140	6300
SX1.200	Stainless Steel	234	324	200	7200
MSX1.140	Mild Steel	234	324	140	6300
MSX1.200	Mild Steel	234	324	200	7200

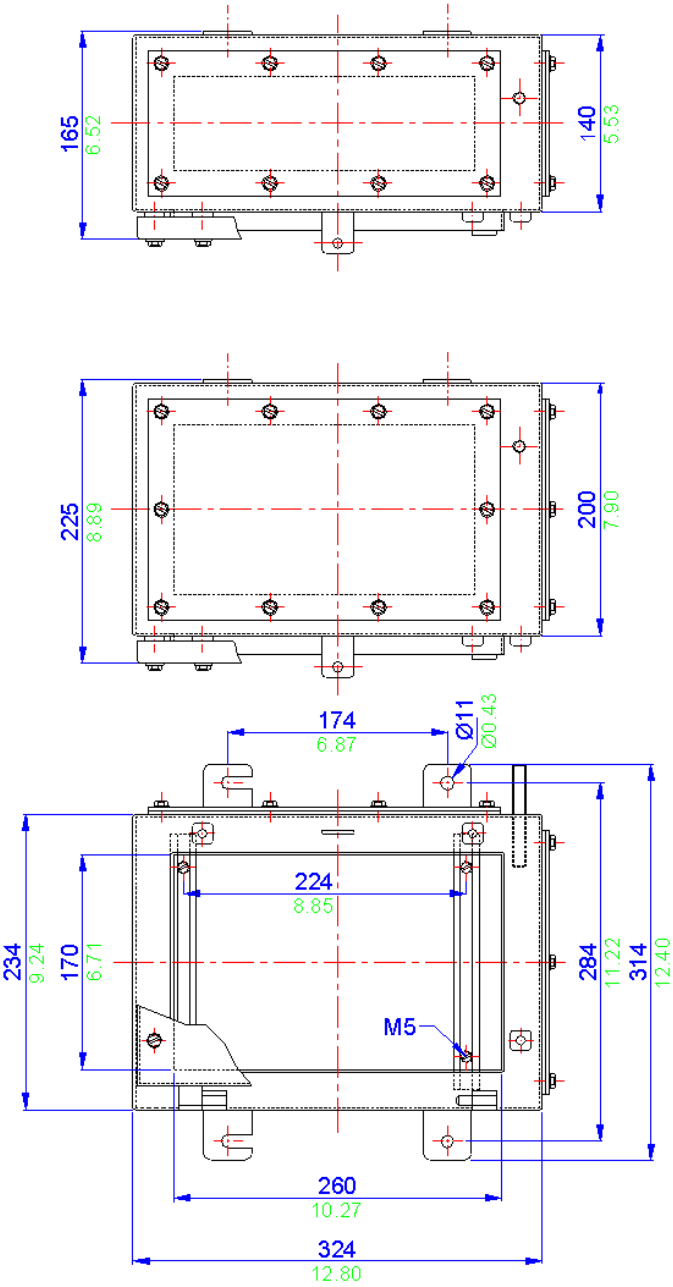

All blue dimensions in mm, all green dimensions in decimal inches (drawing not to scale)

### Application

Hazardous and Industrial areas

### Protection Degree

IP66 or 67

### Certification

ATEX & IECEx (Zone 0, 1 & 2; Zone 20, 21 & 22)  
 CSA Ex e (Class 1 Zone 1 & Zone 2)  
 FM AEx e (Class 1 Zone 1 & Zone 2)  
 TR CU Ex e (Zone 1 & Zone 2)  
 NEMA 4X (CSA, UL & FM)  
 Class 1 Division 2

### Material

Stainless steel 316 (1.4404) or Mild steel

### Temperature Rating

Hazardous Area: -50°C to +175°C  
 Non Hazardous: -60°C to +200°C

### Power Rating

32.284W



### Terminal Populations (Maximum Number of Rails = 3)

Calculations do not include the use of end stops, end plates and separators. Check that the enclosure can accommodate the cable bending radius and that the earth stud and entry location will permit the required number of terminals to be fitted

Weidmuller	
SAK 2.5	99
SAK 4	93
SAK 6	75
SAK 10	60
SAK 16	34
SAK 35	24
SAK 70	20
WDU 2.5	118
WDU 4	99
WDU 6	75
WDU 10	60
WDU 16	34

Phoenix	
UK 2.5 N	120
UK 3 N	120
UK 5 N	99
UK 10 N	60
UK 16 N	34
UK 35 N	26

Wago	
280-992	74
280-999	74
281-691	64
281-992	64
281-993	64
282-691	48
284-691	38
283-691	32
285-691	11
280-998	74
281-998	64
264-120	99
264-220	60
264-132(2)	21
264-134(4)	15
262-132(2)	21
264-134(4)	15

### Drilling Envelope Dimensions (mm)

	Side A - C		Side B - D	
	140	200	140	200
Width	241	241	221	221
Height	75	135	75	135

\* With glandplate fitted

### Gland Entry Matrix \*

Size	Side A - C		Side B - D	
	140	200	140	200
M16	14	28	12	25
M20	10	18	10	16
M25	5	12	4	12
M32	4	8	3	6
M40	3	6	3	4

\* Using standard gland clearances

### Specifications

Part Number	Material	Width (mm)	Length (mm)	Depth (mm)	Weight (g)
SX1.5.140	Stainless Steel	306	306	140	7300
SX1.5.200	Stainless Steel	306	306	200	8800
SX1.5.300	Stainless Steel	306	306	300	11300
MSX1.5.140	Mild Steel	306	306	140	7300
MSX1.5.200	Mild Steel	306	306	200	8800
MSX1.5.300	Mild Steel	306	306	300	11300

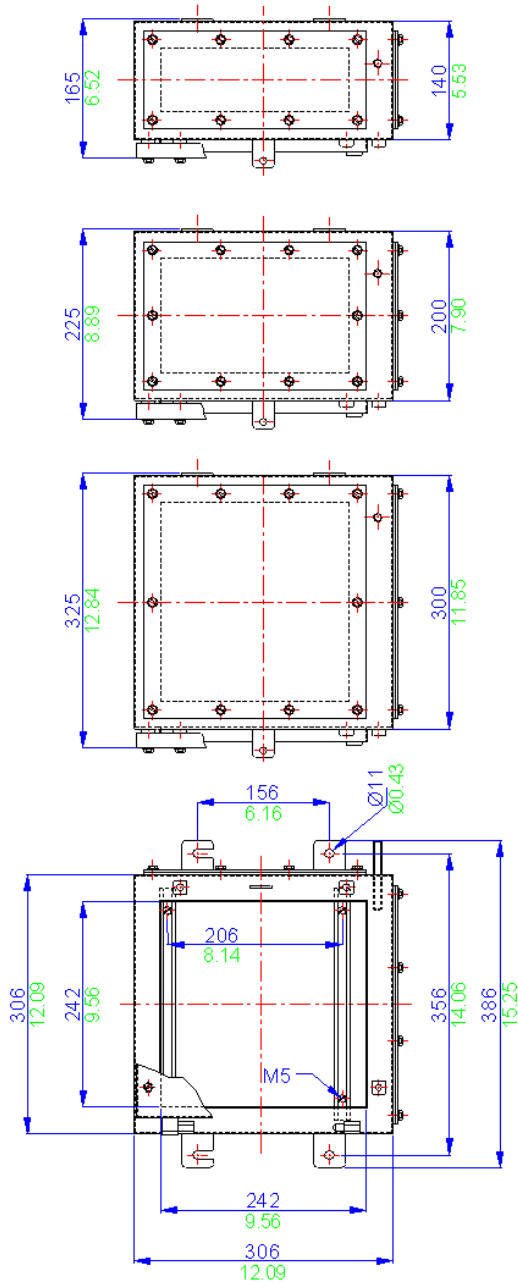

All blue dimensions in mm, all green dimensions in decimal inches (drawing not to scale)

**Application**

Hazardous and Industrial areas

**Protection Degree**

IP66 or 67

**Certification**

ATEX & IECEx (Zone 0, 1 & 2; Zone 20, 21 & 22)  
 CSA Ex e (Class 1 Zone 1 & Zone 2)  
 FM AEx e (Class 1 Zone 1 & Zone 2)  
 TR CU Ex e (Zone 1 & Zone 2)  
 NEMA 4X (CSA, UL & FM)  
 Class 1 Division 2

**Material**

Stainless steel 316 (1.4404) or Mild steel

**Temperature Rating**

Hazardous Area: -50°C to +175°C  
 Non Hazardous: -60°C to +200°C

**Power Rating**

36.500W



**Terminal Populations (Maximum Number of Rails = 3)**

Calculations do not include the use of end stops, end plates and separators. Check that the enclosure can accommodate the cable bending radius and that the earth stud and entry location will permit the required number of terminals to be fitted

Weidmüller	
SAK 2.5	132
SAK 4	123
SAK 6	99
SAK 10	78
SAK 16	66
SAK 35	42
SAK 70	24
WDU 2.5	129
WDU 4	132
WDU 6	99
WDU 10	78
WDU 16	66

Phoenix	
UK 2.5 N	156
UK 3 N	156
UK 5 N	132
UK 10 N	78
UK 16 N	66
UK 35 N	54

Wago	
280-992	150
280-999	150
281-691	126
281-992	126
281-993	84
282-691	99
284-691	78
283-691	44
285-691	30
280-998	150
281-998	126
264-120	132
264-220	78
264-132(2)	27
264-134(4)	18
262-132(2)	27
264-134(4)	18

**Drilling Envelope Dimensions (mm)**

	Side A - C		Side B - D	
	140	200	140	200
Width	307	307	239	239
Height	75	135	75	135

\* With glandplate fitted

**Gland Entry Matrix \***

Size	Side A - C		Side B - D	
	140	200	140	200
M16	18	36	14	28
M20	14	24	10	18
M25	6	18	6	12
M32	5	10	4	8
M40	4	8	3	6

\* Using standard gland clearances

**Specifications**

Part Number	Material	Width (mm)	Length (mm)	Depth (mm)	Weight (g)
SX2.140	Stainless Steel	372	324	140	9500
SX2.200	Stainless Steel	372	324	200	11300
SX2.300	Stainless Steel	372	324	300	14300
MSX2.140	Mild Steel	372	324	140	9500
MSX2.200	Mild Steel	372	324	200	11300
MSX2.300	Mild Steel	372	324	300	14300

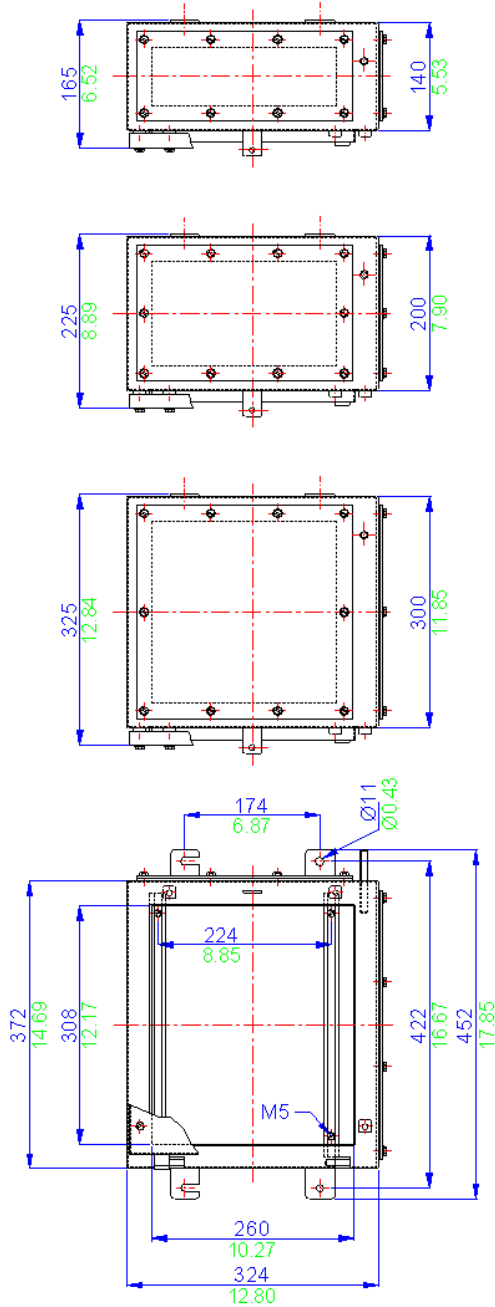

All blue dimensions in mm, all green dimensions in decimal inches (drawing not to scale)

**Application**

Hazardous and Industrial areas

**Protection Degree**

IP66 or 67

**Certification**

ATEX & IECEx (Zone 0, 1 & 2; Zone 20, 21 & 22)  
 CSA Ex e (Class 1 Zone 1 & Zone 2)  
 FM AEx e (Class 1 Zone 1 & Zone 2)  
 TR CU Ex e (Zone 1 & Zone 2)  
 NEMA 4X (CSA, UL & FM)  
 Class 1 Division 2

**Material**

Stainless steel 316 (1.4404) or Mild steel

**Temperature Rating**

Hazardous Area: -50°C to +175°C  
 Non Hazardous: -60°C to +200°C

**Power Rating**

42.289W



**Terminal Populations (Maximum Number of Rails = 3)**

Calculations do not include the use of end stops, end plates and separators. Check that the enclosure can accommodate the cable bending radius and that the earth stud and entry location will permit the required number of terminals to be fitted

Weidmuller	
SAK 2.5	168
SAK 4	156
SAK 6	126
SAK 10	102
SAK 16	84
SAK 35	63
SAK 70	45
WDU 2.5	201
WDU 4	168
WDU 6	126
WDU 10	102
WDU 16	84

Phoenix	
UK 2.5 N	201
UK 3 N	201
UK 5 N	168
UK 10 N	102
UK 16 N	84
UK 35 N	69

Wago	
280-992	189
280-999	189
281-691	162
281-992	162
281-993	108
282-691	126
284-691	99
283-691	56
285-691	38
280-998	189
281-998	162
264-120	168
264-220	99
264-132(2)	36
264-134(4)	24
262-132(2)	36
264-134(4)	24

**Drilling Envelope Dimensions (mm)**

	Side A - C		Side B - D	
	140	200	140	200
Width	307	307	363	363
Height	75	135	75	135

\* With glandplate fitted

**Gland Entry Matrix \***

Size	Side A - C		Side B - D	
	140	200	140	200
M16	16	36	20	45
M20	12	24	16	28
M25	7	15	8	21
M32	5	10	6	12
M40	4	8	5	8

\* Using standard gland clearances

**Specifications**

Part Number	Material	Width (mm)	Length (mm)	Depth (mm)	Weight (g)
SX3.140	Stainless Steel	372	448	140	11300
SX3.200	Stainless Steel	372	448	200	13300
SX3.300	Stainless Steel	372	448	300	16600
MSX3.140	Mild Steel	372	448	140	11300
MSX3.200	Mild Steel	372	448	200	13300
MSX3.300	Mild Steel	372	448	300	16600

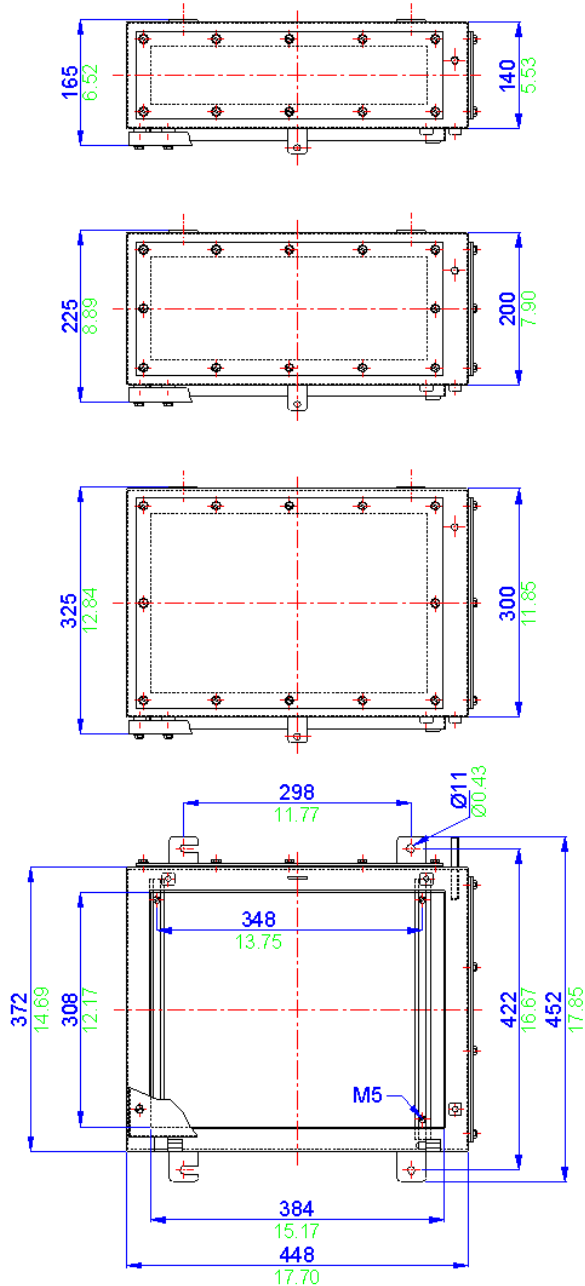

All blue dimensions in mm, all green dimensions in decimal inches (drawing not to scale)



**Application**  
Hazardous and Industrial areas

**Protection Degree**  
IP66 or 67

**Certification**  
ATEX & IECEx (Zone 0, 1 & 2; Zone 20, 21 & 22)  
CSA Ex e (Class 1 Zone 1 & Zone 2)  
FM AEx e (Class 1 Zone 1 & Zone 2)  
TR CU Ex e (Zone 1 & Zone 2)  
NEMA 4X (CSA, UL & FM)  
Class 1 Division 2

**Material**  
Stainless steel 316 (1.4404) or Mild steel

**Temperature Rating**  
Hazardous Area: -50°C to +175°C  
Non Hazardous: -60°C to +200°C

**Power Rating**  
44.726W



**Terminal Populations (Maximum Number of Rails = 3)**

Calculations do not include the use of end stops, end plates and separators. Check that the enclosure can accommodate the cable bending radius and that the earth stud and entry location will permit the required number of terminals to be fitted

Weidmuller	
SAK 2.5	198
SAK 4	183
SAK 6	150
SAK 10	120
SAK 16	99
SAK 35	75
SAK 70	54
WDU 2.5	237
WDU 4	198
WDU 6	150
WDU 10	120
WDU 16	99

Phoenix	
UK 2.5 N	237
UK 3 N	237
UK 5 N	198
UK 10 N	102
UK 16 N	99
UK 35 N	81

Wago	
280-992	222
280-999	222
281-691	189
281-992	189
281-993	126
282-691	147
284-691	117
283-691	66
285-691	44
280-998	222
281-998	189
264-120	198
264-220	117
264-132(2)	42
264-134(4)	30
262-132(2)	42
264-134(4)	30

**Drilling Envelope Dimensions (mm)**

	Side A - C		Side B - D	
	140	200	140	200
Width	307	307	425	425
Height	75	135	75	135

\* With glandplate fitted

**Gland Entry Matrix \***

Size	Side A - C		Side B - D	
	140	200	140	200
M16	18	36	26	52
M20	14	24	20	36
M25	6	18	10	24
M32	5	10	7	14
M40	4	8	6	10

\* Using standard gland clearances

**Specifications**

Part Number	Material	Width (mm)	Length (mm)	Depth (mm)	Weight (g)
SX4.140	Stainless Steel	372	510	140	12700
SX4.200	Stainless Steel	372	510	200	14800
SX4.300	Stainless Steel	372	510	300	18300
MSX4.140	Mild Steel	372	510	140	12700
MSX4.200	Mild Steel	372	510	200	14800
MSX4.300	Mild Steel	372	510	300	18300

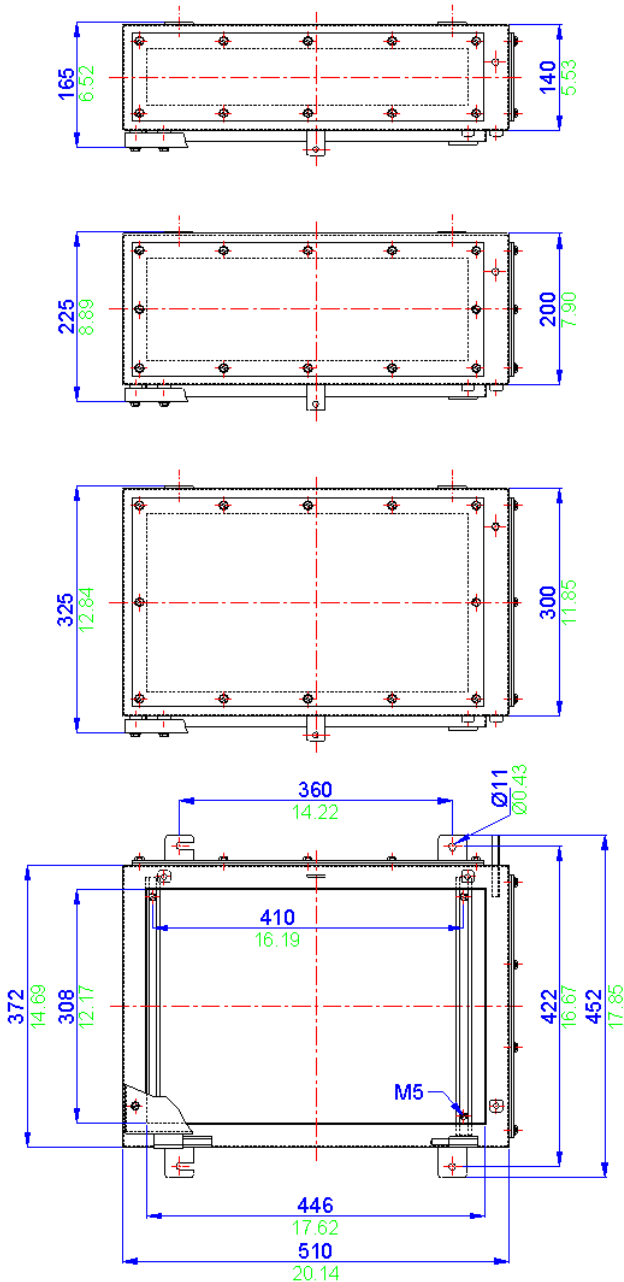

All blue dimensions in mm, all green dimensions in decimal inches (drawing not to scale)

### Application

Hazardous and Industrial areas

### Protection Degree

IP66 or 67

### Certification

ATEX & IECEx (Zone 0, 1 & 2; Zone 20, 21 & 22)  
 CSA Ex e (Class 1 Zone 1 & Zone 2)  
 FM AEx e (Class 1 Zone 1 & Zone 2)  
 TR CU Ex e (Zone 1 & Zone 2)  
 NEMA 4X (CSA, UL & FM)  
 Class 1 Division 2

### Material

Stainless steel 316 (1.4404) or Mild steel

### Temperature Rating

Hazardous Area: -50°C to +175°C  
 Non Hazardous: -60°C to +200°C

### Power Rating

50.328W



### Terminal Populations (Maximum Number of Rails = 4)

Calculations do not include the use of end stops, end plates and separators. Check that the enclosure can accommodate the cable bending radius and that the earth stud and entry location will permit the required number of terminals to be fitted

Weidmuller	
SAK 2.5	264
SAK 4	244
SAK 6	200
SAK 10	160
SAK 16	132
SAK 35	100
SAK 70	72
WDU 2.5	316
WDU 4	264
WDU 6	200
WDU 10	160
WDU 16	132

Phoenix	
UK 2.5 N	316
UK 3 N	316
UK 5 N	264
UK 10 N	160
UK 16 N	132
UK 35 N	108

Wago	
280-992	296
280-999	296
281-691	252
281-992	252
281-993	189
282-691	196
284-691	156
283-691	99
285-691	66
280-998	296
281-998	252
264-120	264
264-220	156
264-132(2)	56
264-134(4)	40
262-132(2)	56
264-134(4)	40

### Drilling Envelope Dimensions (mm)

	Side A - C		Side B - D	
	140	200	140	200
Width	445	445	425	425
Height	75	135	75	135

\* With glandplate fitted

### Gland Entry Matrix \*

Size	Side A - C		Side B - D	
	140	200	140	200
M16	26	55	26	52
M20	20	36	20	36
M25	10	27	10	24
M32	7	14	7	14
M40	6	12	6	10

\* Using standard gland clearances

### Specifications

Part Number	Material	Width (mm)	Length (mm)	Depth (mm)	Weight (g)
SX5.140	Stainless Steel	510	510	140	17000
SX5.200	Stainless Steel	510	510	200	20000
SX5.300	Stainless Steel	510	510	300	25000
MSX5.140	Mild Steel	510	510	140	17000
MSX5.200	Mild Steel	510	510	200	20000
MSX5.300	Mild Steel	510	510	300	25000

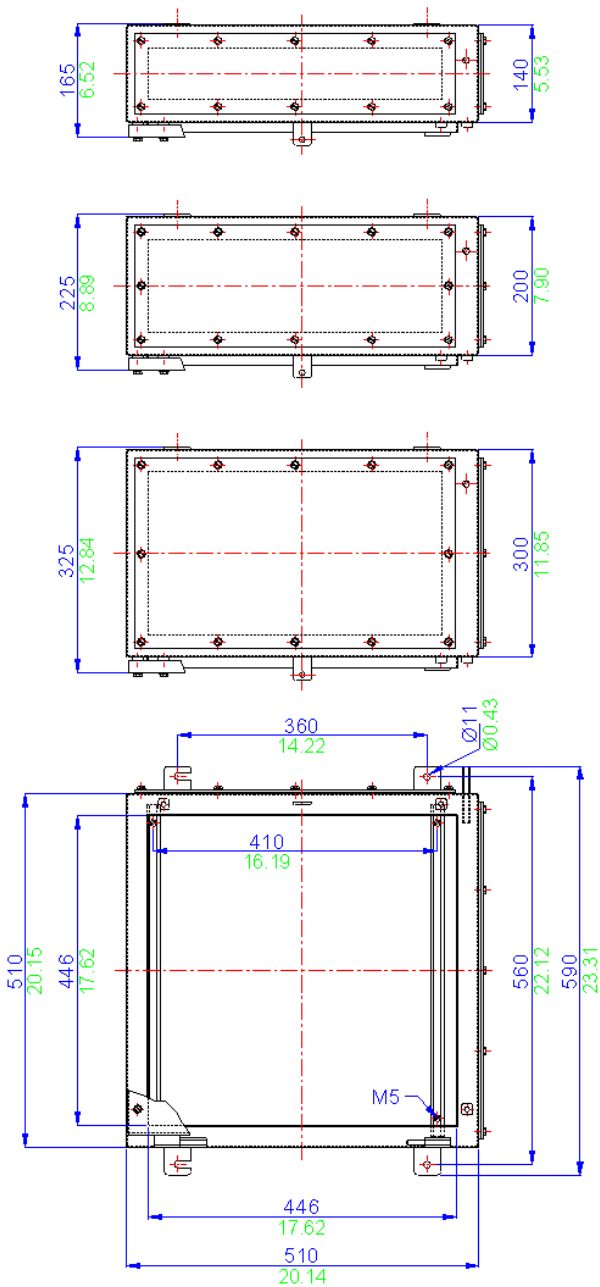

All blue dimensions in mm, all green dimensions in decimal inches (drawing not to scale)

### Application

Hazardous and Industrial areas

### Protection Degree

IP66 or 67

### Certification

ATEX & IECEx (Zone 0, 1 & 2; Zone 20, 21 & 22)  
 CSA Ex e (Class 1 Zone 1 & Zone 2)  
 FM AEx e (Class 1 Zone 1 & Zone 2)  
 TR CU Ex e (Zone 1 & Zone 2)  
 NEMA 4X (CSA, UL & FM)  
 Class 1 Division 2

### Material

Stainless steel 316 (1.4404) or Mild steel

### Temperature Rating

Hazardous Area: -50°C to +175°C  
 Non Hazardous: -60°C to +200°C

### Power Rating

57.383W



### Terminal Populations (Maximum Number of Rails = 4)

Calculations do not include the use of end stops, end plates and separators. Check that the enclosure can accommodate the cable bending radius and that the earth stud and entry location will permit the required number of terminals to be fitted

Weidmuller	
SAK 2.5	440
SAK 4	404
SAK 6	332
SAK 10	264
SAK 16	220
SAK 35	168
SAK 70	120
WDU 2.5	528
WDU 4	440
WDU 6	332
WDU 10	264
WDU 16	220

Phoenix	
UK 2.5 N	524
UK 3 N	524
UK 5 N	440
UK 10 N	264
UK 16 N	229
UK 35 N	176

Wago	
280-992	496
280-999	496
281-691	424
281-992	424
281-993	318
282-691	328
284-691	264
283-691	165
285-691	114
280-998	496
281-998	424
264-120	440
264-220	264
264-132(2)	92
264-134(4)	64
262-132(2)	92
264-134(4)	64

### Drilling Envelope Dimensions (mm)

	Side A - C		Side B - D	
	140	200	140	200
Width	445	445	695	695
Height	75	135	75	135

\* With glandplate fitted

### Gland Entry Matrix \*

Size	Side A - C		Side B - D	
	140	200	140	200
M16	26	55	42	85
M20	20	36	34	60
M25	10	27	18	42
M32	7	14	11	22
M40	6	12	10	18

\* Using standard gland clearances

### Specifications

Part Number	Material	Width (mm)	Length (mm)	Depth (mm)	Weight (g)
SX6.140	Stainless Steel	510	780	140	24000
SX6.200	Stainless Steel	510	780	200	27000
SX6.300	Stainless Steel	510	780	300	32000
MSX6.140	Mild Steel	510	780	140	24000
MSX6.200	Mild Steel	510	780	200	27000
MSX6.300	Mild Steel	510	780	300	32000

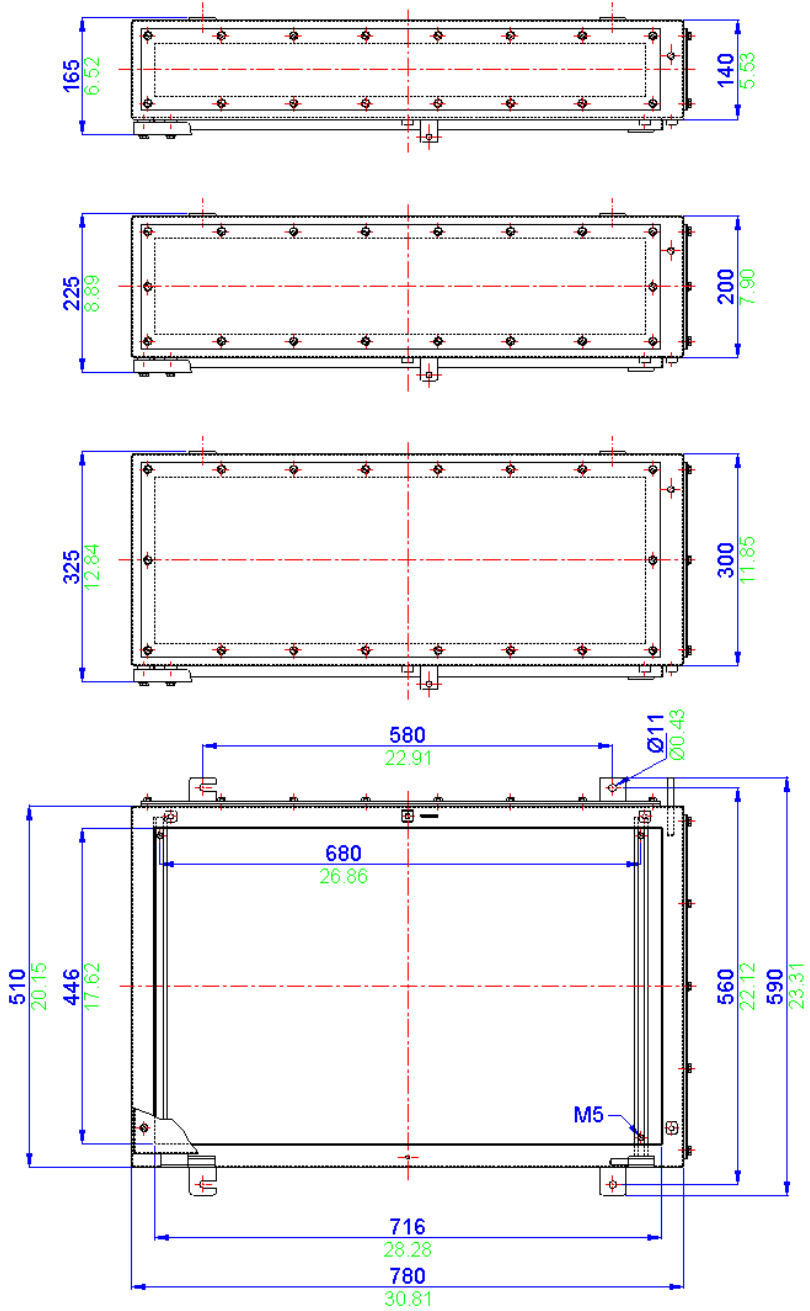

All blue dimensions in mm, all green dimensions in decimal inches (drawing not to scale)

### Application

Hazardous and Industrial areas

### Protection Degree

IP66 or 67

### Certification

ATEX & IECEx (Zone 0, 1 & 2; Zone 20, 21 & 22)  
 CSA Ex e (Class 1 Zone 1 & Zone 2)  
 FM AEx e (Class 1 Zone 1 & Zone 2)  
 TR CU Ex e (Zone 1 & Zone 2)  
 NEMA 4X (CSA, UL & FM)  
 Class 1 Division 2

### Material

Stainless steel 316 (1.4404) or Mild steel

### Temperature Rating

Hazardous Area: -50°C to +175°C  
 Non Hazardous: -60°C to +200°C

### Power Rating

68.000W



### Terminal Populations (Maximum Number of Rails = 5)

Calculations do not include the use of end stops, end plates and separators. Check that the enclosure can accommodate the cable bending radius and that the earth stud and entry location will permit the required number of terminals to be fitted

Weidmuller	
SAK 2.5	685
SAK 4	635
SAK 6	520
SAK 10	415
SAK 16	345
SAK 35	260
SAK 70	150
WDU 2.5	822
WDU 4	685
WDU 6	520
WDU 10	415
WDU 16	345

Phoenix	
UK 2.5 N	820
UK 3 N	820
UK 5 N	685
UK 10 N	415
UK 16 N	345
UK 35 N	280

Wago	
280-992	775
280-999	775
281-691	660
281-992	660
281-993	528
282-691	510
284-691	410
283-691	272
285-691	188
280-998	775
281-998	660
264-120	685
264-220	410
264-132(2)	145
264-134(4)	100
262-132(2)	145
264-134(4)	100

### Drilling Envelope Dimensions (mm)

	Side A - C		Side B - D	
	140	200	140	200
Width	585	585	865	865
Height	75	135	75	135

\* With glandplate fitted

### Gland Entry Matrix \*

Size	Side A - C		Side B - D	
	140	200	140	200
M16	36	72	54	110
M20	28	48	42	72
M25	14	36	22	54
M32	10	20	14	28
M40	8	16	12	24

\* Using standard gland clearances

### Specifications

Part Number	Material	Width (mm)	Length (mm)	Depth (mm)	Weight (g)
SX7.140	Stainless Steel	650	950	140	35000
SX7.200	Stainless Steel	650	950	200	39000
SX7.300	Stainless Steel	650	950	300	45000
MSX7.140	Mild Steel	650	950	140	35000
MSX7.200	Mild Steel	650	950	200	39000
MSX7.300	Mild Steel	650	950	300	45000

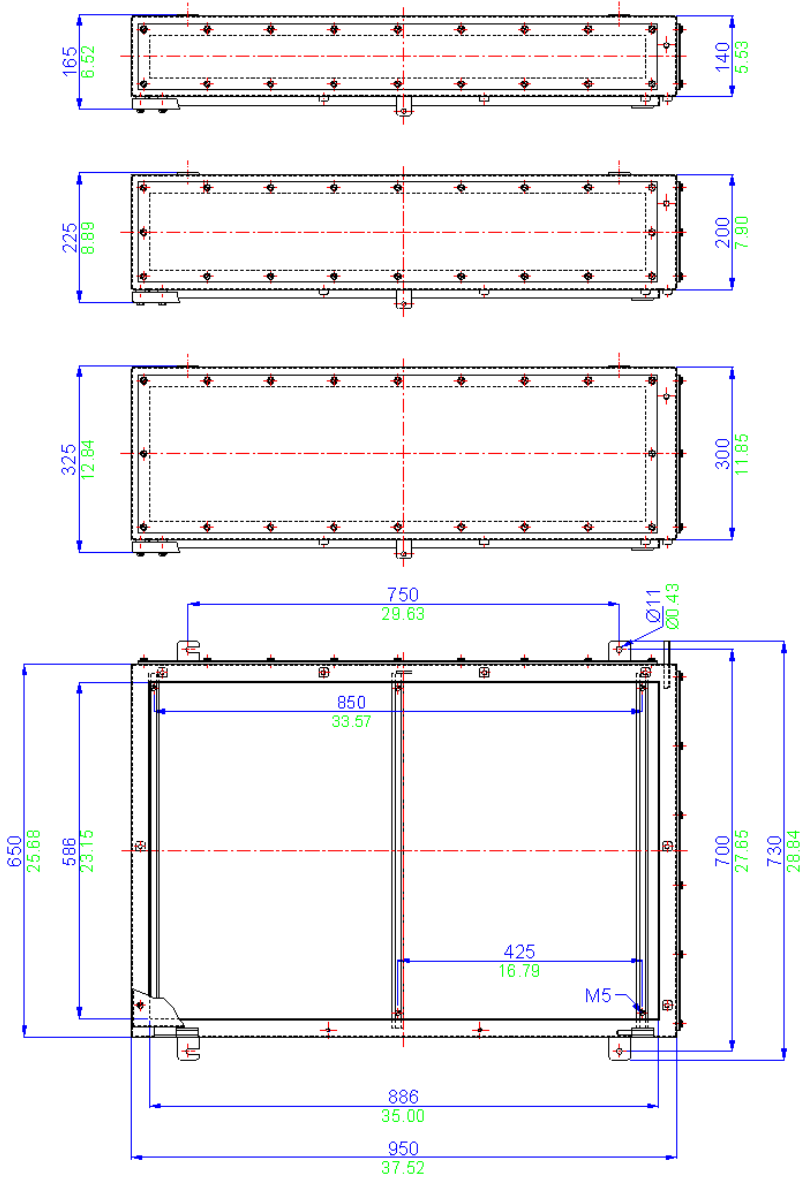

All blue dimensions in mm, all green dimensions in decimal inches (drawing not to scale)



### Application

Hazardous and Industrial areas

### Protection Degree

IP66 or 67

### Certification

ATEX & IECEx (Zone 0, 1 & 2; Zone 20, 21 & 22)  
 CSA Ex e (Class 1 Zone 1 & Zone 2)  
 FM AEx e (Class 1 Zone 1 & Zone 2)  
 TR CU Ex e (Zone 1 & Zone 2)  
 NEMA 4X (CSA, UL & FM)  
 Class 1 Division 2

### Material

Stainless steel 316 (1.4404) or Mild steel

### Temperature Rating

Hazardous Area: -50°C to +175°C  
 Non Hazardous: -60°C to +200°C

### Power Rating

119.462W



### Terminal Populations (Maximum Number of Rails = 5)

Calculations do not include the use of end stops, end plates and separators. Check that the enclosure can accommodate the cable bending radius and that the earth stud and entry location will permit the required number of terminals to be fitted

Weidmuller	
SAK 2.5	1295
SAK 4	635
SAK 6	520
SAK 10	415
SAK 16	345
SAK 35	260
SAK 70	150
WDU 2.5	1554
WDU 4	1295
WDU 6	520
WDU 10	415
WDU 16	345

Phoenix	
UK 2.5 N	820
UK 3 N	820
UK 5 N	685
UK 10 N	415
UK 16 N	345
UK 35 N	280

Wago	
280-992	775
280-999	775
281-691	660
281-992	660
281-993	528
282-691	510
284-691	410
283-691	272
285-691	188
280-998	775
281-998	660
264-120	685
264-220	410
264-132(2)	145
264-134(4)	100
262-132(2)	145
264-134(4)	100

### Drilling Envelope Dimensions (mm)

	Side A - C		Side B - D	
	140	200	140	200
Width	735	735	1165	1165
Height	75	135	75	135

\* With glandplate fitted

### Gland Entry Matrix \*

Size	Side A - C		Side B - D	
	140	200	140	200
M16	45	90	72	150
M20	36	60	58	100
M25	18	45	30	72
M32	12	24	20	40
M40	10	20	17	32

\* Using standard gland clearances

### Specifications

Part Number	Material	Width (mm)	Length (mm)	Depth (mm)	Weight (g)
SX8.140	Stainless Steel	800	1250	140	40000
SX8.200	Stainless Steel	800	1250	200	52000
SX8.300	Stainless Steel	800	1250	300	72000
MSX8.140	Mild Steel	800	1250	140	40000
MSX8.200	Mild Steel	800	1250	200	52000
MSX8.300	Mild Steel	800	1250	300	72000

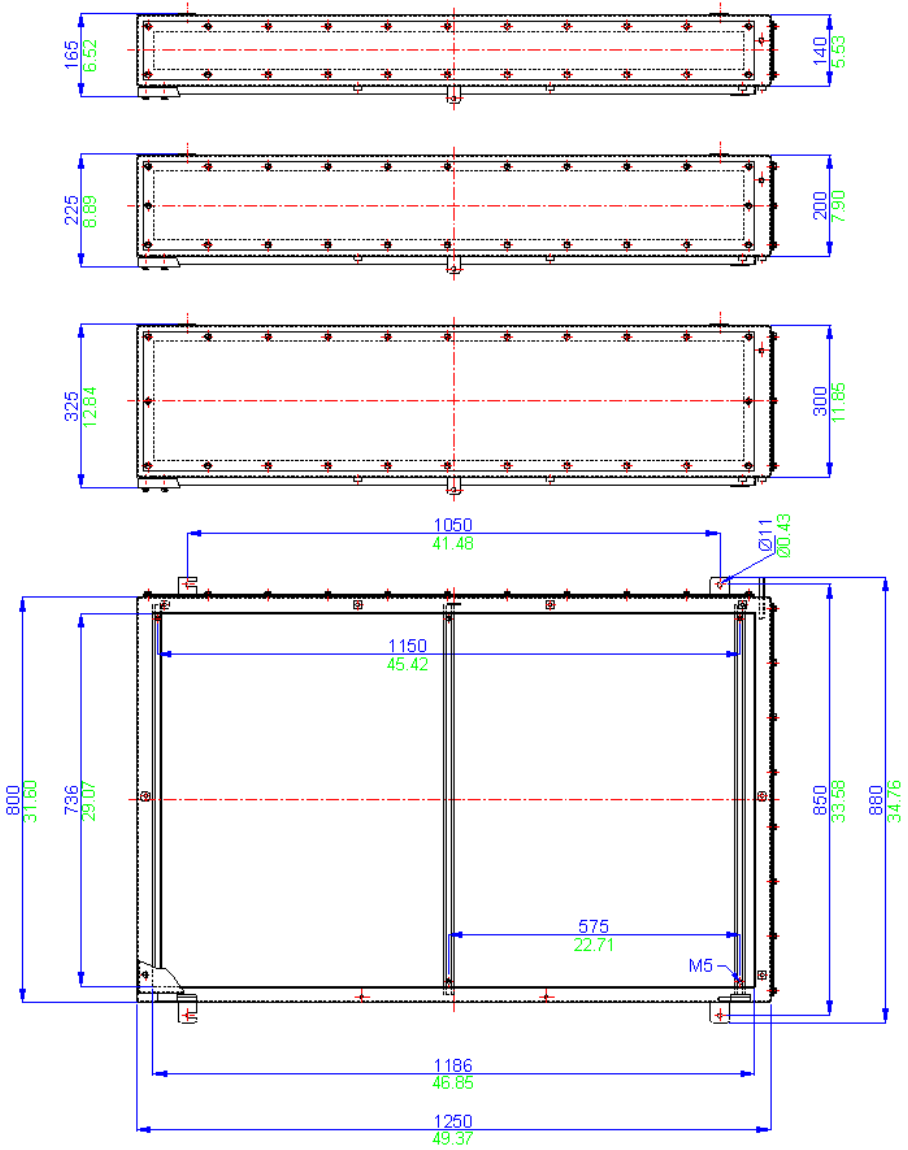

All blue dimensions in mm, all green dimensions in decimal inches (drawing not to scale)